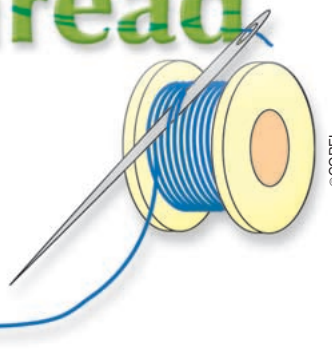


# Feedback Control: An Invisible Thread in the History of Technology



By Dennis S. Bernstein

**T**he history of technology is a rich and fascinating subject, combining engineering with economic, social, and political factors. Technology seems to advance in waves. Small advances in science and technology accumulate slowly, sometimes over long periods of time, until a critical level of technological success and economic advantage is achieved. The last century witnessed several of these waves: automobiles, radio, aircraft, television, and computers, each of which had a profound effect on civilization.

Woven into the rich fabric of technological history is an invisible thread that has had a profound effect on each of these waves and earlier ones as well. This thread is the idea of feedback control. Like all ideas, feedback control impacts technology only when it is embodied in technology; it is not tied to any specific technological innovation or invention.

The purpose of this article is to describe technological innovations that either use feedback control or allow feedback control to be exploited. While remarkable in their simplicity, these inventions are profound in their impact on technology. In fact, we shall show that these innovations played a crucial role in facilitating the truly great waves of technological and scientific development, namely, the Scientific Revolution, the Industrial Revolution, the Age of Aviation, the Space Age, and the Age of Electronics. These innovations are the escapement, the governor, the aileron, the gyro, and the amplifier.

## The Escapement

For Mercury there is, beyond the correction at leap year, provision for a secondary correction after 144 years by setting the wheel M forward 1 tooth. In the argument of Mercury there is an annual deficit of  $42'5''$ , so that the dial should be set forward  $2/3^\circ$  annually with a residual correction of  $1^\circ$  in 29 years.

— Giovanni di Dondi, describing the procedure for maintaining his astronomical clock completed in 1364 [Gimpel, 1976, p. 165]

The Kelantese approach to time is typified by their coconut clocks—an invention they use as a timer for sporting competitions. This clock consists of a half coconut shell with a small hole in its center that sits in a pail of water. Intervals are measured by the time it takes the shell to fill with water and then sink—usually about three to five minutes. The Kelantese recognize that the clock is inexact, but they choose it over the wristwatches they own.

—[Levine, 1997, p. 93]

In the early 15th century, the Western world was only dimly aware of the outlines of the world at large. As sailing

---

*The author (dsbaero@umich.edu) is with the Aerospace Engineering Department, 1320 Beal St., University of Michigan, Ann Arbor, MI 48109, U.S.A.*

technology improved, Portuguese ships explored the uncharted coast of Africa, a daring exploit. It was a full 70 years before da Gama rounded the southern tip of Africa and reached India in 1498. This age of exploration included the accidental Western discovery of the New World and affected indigenous civilizations for better or worse around the globe.

In his quest to reach China, Columbus used a second-century map of Ptolemy, which underestimated the size of the earth. Fortunately for Columbus, he discovered a way station (and obstacle) en route. One difficult aspect of ocean journeys was the problem of navigation, in particular, that of determining longitude at sea. Rough estimates of distance could be obtained by dead reckoning, which involved a compass for determining direction and a means for timing an object floating by the ship to estimate speed;

but this method was not very accurate. The consequences of getting lost at sea were extremely serious and included the ship's crew starving to death or dying of scurvy, as well as the ship being destroyed on rocky shores during foggy weather.

The problem of determining longitude was eventually solved by the mechanical clock. The hero of that story is John Harrison (1733-1766), a British clockmaker who spent 30 years designing, building, and refining what are considered the most exquisite and innovative mechanical timepieces ever built.

Before the advent of the mechanical clock, time was measured by means of water clocks, hourglasses, sundials, graduated candles, and many other devices. All of these had deficiencies in their operation and accuracy. In the last part of the 13th century, an alternative technology arose, the me-

## Clocks

- G.B. Airy, "On the disturbances of pendulums and balances, and on the theory of escapements," *Trans. Cambridge Phil. Soc.*, vol. III, part 1, pp. 105-128, 1830.
- W.J.H. Andrewes, Ed., *The Quest for Longitude*, 2nd. ed. Cambridge, MA: Harvard Univ., Collection of Historical Scientific Instruments, 1998.
- A.A. Andronov, A.A. Vitt, and S.E. Khaikin, *Theory of Oscillators*. Oxford: Pergamon Press, 1966. Reprinted by New York: Dover, 1987.
- J.E. Barnett, *Time's Pendulum: From Sundials to Atomic Clocks, the Fascinating History of Timekeeping and How Our Discoveries Changed the World*. San Diego, CA: Harcourt Brace, 1998.
- F.J. Britton, *The Escapements: Their Action, Construction, and Proportion*. Chicago, IL: Hazlitt, undated. Reprinted by Arlington: Arlington Books, 1984.
- C.M. Cipolla, *Clocks and Culture 1300-1700*. New York: Norton, 1978.
- G. Dohrn-van Rossum, *History of the Hour: Clocks and Modern Temporal Orders*. Chicago, IL: Univ. of Chicago Press, 1996.
- H.B. Fried, *The Watch Escapement*. New York: Columbia Communications, 1974.
- W.J. Gazely, *Clock and Watch Escapements*. London: Heywood, 1956.
- F. Gies and J. Gies, *Cathedral, Forge, and Waterwheel: Technology and Invention in the Middle Ages*. New York: Harper Perennial, 1994.
- J. Gimpel, *The Medieval Machine: The Industrial Revolution of the Middle Ages*. New York: Penguin, 1976.
- C. Schwartz and R. Gran, "Describing function analysis using MATLAB," *IEEE Contr. Sys. Mag.*, vol. 21, pp. 19-26, Aug. 2001.
- M.V. Headrick, *Clock and Watch Escapement Mechanics*. [Online] 1997. Available: <http://mvheadrick.free.fr/clocklinks.html>
- L. Jardine, *Ingenious Pursuits: Building the Scientific Revolution*. New York: Doubleday, 1999.
- M. Kesteven, "On the mathematical theory of clock escapements," *Amer. J. Physics*, vol. 46, no. 2, pp. 125-129, 1978.
- D.S. Landes, *Revolution in Time: Clocks and the Making of the Modern World*, rev. ed. Cambridge, MA: Harvard Univ. Press, 2000.
- A.M. Lepschy, G.A. Mian, and U. Viaro, "Feedback control in ancient water and mechanical clocks," *IEEE Trans. Educ.*, vol. 35, no. 1, pp. 3-10, 1992.
- R. Levine, *A Geography of Time*. New York: Basic Books, 1997.
- H.A. Lloyd, *Some Outstanding Clocks over Seven Hundred Years 1250-1950*. London: Leonard Hill, 1958.
- K. Maurice and O. Mayr, *The Clockwork Universe: German Clocks and Automata, 1550-1650*. Washington, D.C.: Smithsonian Institution, 1980.
- J.C. Pellaton, *Watch Escapements*, 3rd. ed. London: NAG Press, undated.
- L. Penman, *Practical Clock Escapements*. Shingle Springs, CA: Clockworks Press Int., 1998.
- J.H. Reid, "The measurement of time," *J. Roy. Astron. Soc. Canada*, vol. 66, no. 3, pp. 135-148, 1972.
- A. Roup and D.S. Bernstein, "On the dynamics of the escapement mechanism of a mechanical clock," in *Proc. Conf. Decision and Control*, Phoenix, AZ, Dec. 1999, pp. 2599-2604.
- A.V. Roup, D.S. Bernstein, S.G. Nersesov, W.M. Haddad, and V. Chellaboina, "Limit cycle analysis of the verge and foliot clock escapement using impulsive differential equations and Poincare maps," *Proc. American Control Conf.*, Arlington, VA, June 2001, pp. 3245-3250
- D. Sobel and W.J.H. Andrewes, *The Illustrated Longitude: The True Story of a Lone Genius Who Solved the Greatest Scientific Problem of His Time*. New York: Walker, 1998.
- C. Sturridge, Director, *Longitude*, DVD or VHS, Aug. 2000.
- J.E.D. Williams, *From Sails to Satellites: The Origin and Development of Navigational Science*. New York: Oxford Univ. Press, 1992.

chanical clock. This technology had advantages, but it was not uniformly better. Mechanical clocks were heavy, expensive, large, and often less accurate than earlier technologies. Clock towers in Europe employed full-time caretakers who used a sundial for periodically resetting the clock, while some early wristwatches had a built-in compass and sundial.

At the heart of every mechanical clock lies a regulator. While early clocks kept time poorly, gradual improvements eventually allowed mechanical clocks to keep time with better accuracy than previous devices such as sundials. The earliest regulator was the verge-and-foliot escapement, which dates from around 1283.

Unfortunately, the inventor of this device is unknown, but it is clear that during this period many craftsmen sought to attain steady, reliable motion by using gears and levers driven by the force of falling weights. The problem was to develop a device with a precise terminal (steady-state) velocity to serve as the clock speed.

The verge-and-foliot escapement consists of a weight-driven crown gear or escape wheel, which interacts with a pair of paddles, or pallets, mounted on a rotating shaft (this is the verge, while the foliot consists of the weights used to adjust the inertia of the shaft) (Fig. 1). Each impact of a pallet with a crown gear tooth momentarily decreases the angular velocity of the crown gear, and the interplay of these two components constitutes feedback action. Alone, each component would rotate endlessly (the crown gear would accelerate), but in feedback the combination reaches a terminal velocity, which determines the clock speed.

From a modern perspective, the verge-and-foliot escapement is a surprising innovation. Previously, time had been kept by the smoothly flowing, continuous dynamics of water, sand, or melting wax. Intuitively, the use of a smoothly flowing substance to measure time seemed reasonable, since time itself appears to flow continuously. Unfortunately, maintaining a constant flow is difficult, and the solution to this problem is as counterintuitive as it is profound. The verge-and-foliot escapement did not attempt to regulate the motion of the falling weight so as to maintain a constant velocity. Instead, the weight would alternately speed up and slow down as the crown gear impacted the verge pallets. Each impact of a pallet with a gear tooth imparts an impulsive force to the crown gear, causing a discontinuity or jump in its velocity.

In short, the verge-and-foliot escapement measured time by packaging it into intervals, namely, the intervals between impacts. With this packaging, time effectively became discretized. To tell time, one would merely need to count the impacts (ticks and tocks), and this counting is a digital process. In addition, the mechanical clock is a discrete-event system, whose dynamics are continuous between impacts and discontinuous at impacts. The dynamics of a verge-and-foliot clock thus depend on the intricate behavior

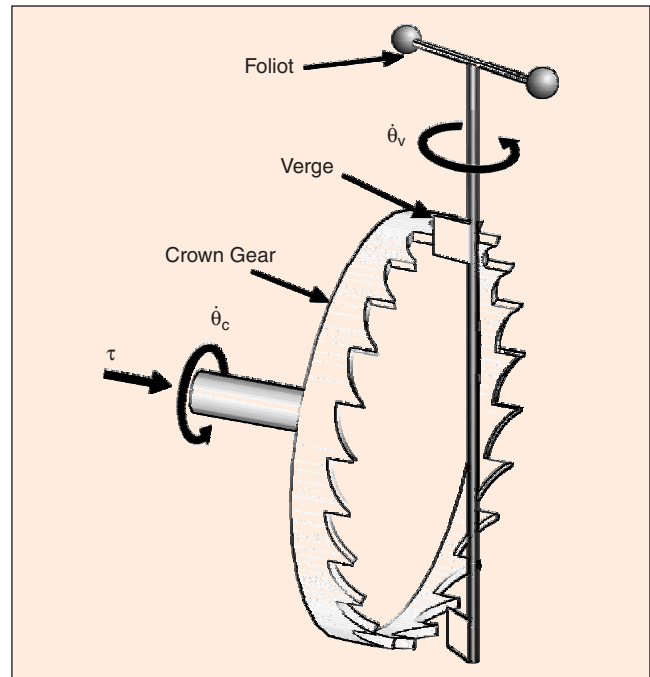
of interacting components. The speed at which the clock runs depends on the dynamics that arise from this interaction. In particular, the period of the limit cycle arises from the coefficients of restitution and friction, as well as the inertia of the various components.

The verge-and-foliot clocks were usually large and constructed of hand-wrought iron. Blacksmiths were enlisted to build them, and large towers were constructed to support

## At the heart of every mechanical clock lies a regulator.

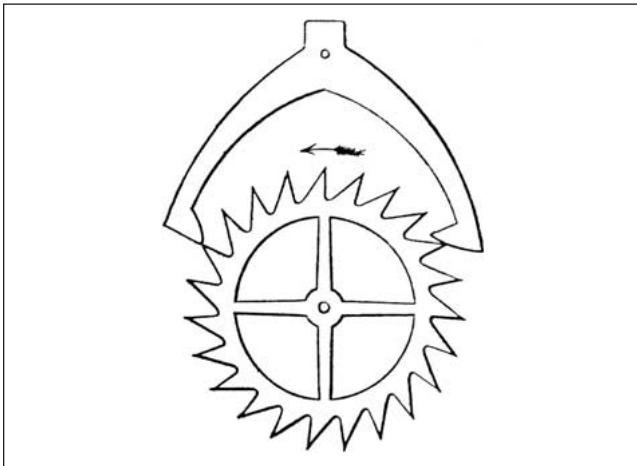
them. The driving weight alone often weighed 1,000 lb. Although these were not especially accurate clocks, to the extent that they did not warrant a minute hand, it is noteworthy that the verge-and-foliot escapement was the only mechanical escapement that we know of from the time of its inception until the middle of the 17th century. What was needed to achieve greater accuracy was an escapement mechanism that could be adjusted in a more precise and repeatable manner.

For the mechanical clock, the next critical advance was the replacement of the swinging verge and foliot and its complicated limit-cycle dynamics with a mechanism that provided its own period largely independent of the interaction with the escape wheel. The crucial observation was made by Galileo (1564-1642), who observed the motion of the swinging altar lamp during a church service. Using his own pulse as a timer, he observed that the period of oscilla-

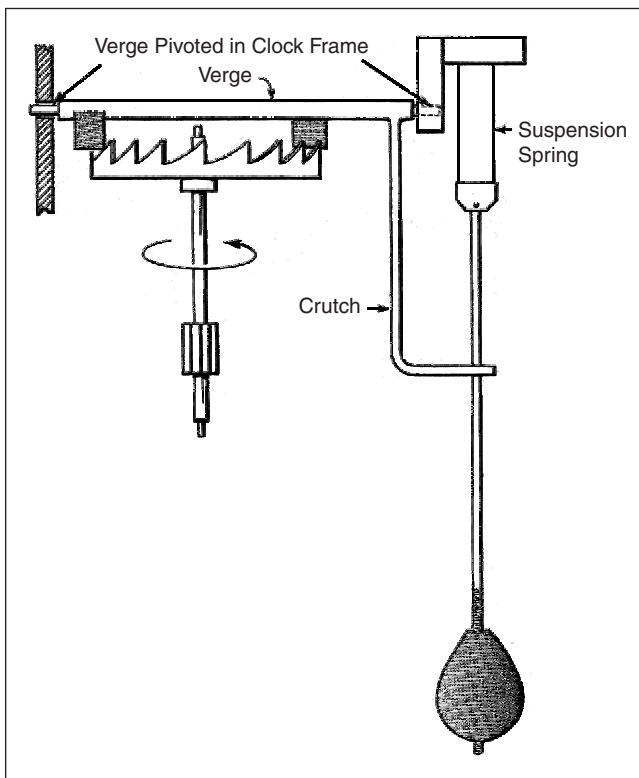


**Figure 1.** The verge and foliot was the earliest clock escapement. Developed in the late 13th century, it remained unchanged until the 17th century.

tion was independent of the amplitude of swing (which is actually only approximately true for small amplitudes). Galileo conceived of a clock based on the pendulum, but he did not live to complete it.



**Figure 2.** The first pendulum clock was developed by Huygens in 1657. This escapement was based on a verge and foliot with the foliot replaced by a pendulum. ([Barnett, 1998, p. 89], reproduced by permission.)



**Figure 3.** The anchor escapement, which appeared in 1671, had an escape wheel and an escape lever that moved in a single plane. The escape lever is attached to a pendulum, and the escape wheel is attached to the hanging weight and clockwork. This compact design had many subsequent variations and, since the escape lever moves through only a few degrees of arc, was considerably more precise than the verge-and-foliot escapement. ([Barnett, 1998, p. 90], reproduced by permission.)

In 1657, the first pendulum clock was realized by Christian Huygens (1629-1695), who modified the verge-and-foliot escapement by replacing the verge and foliot with a pendulum swinging in a vertical plane and with the crown gear mounted horizontally (Fig. 2). However, the basic pallet/gear tooth interaction remained the same. Nevertheless, the dynamics of this clock benefited from the natural period of the pendulum. The reliance on impact was reduced, and the pendulum swung from an elastic flexure, reducing friction. However, since the pendulum swung through a large arc, it suffered from “circular error,” which caused the period to vary with the amplitude. This effect is due to the fact that the pendulum equation has the form  $\ddot{\theta} + (g/\ell)\sin\theta = 0$ , where  $g$  is the acceleration due to gravity and  $\ell$  is the pendulum length. Because of the  $\sin\theta$  term, the period of the pendulum is amplitude dependent. However, for small angles,  $\sin\theta \approx \theta$ , and thus the dynamics of the pendulum approximate those of a simple harmonic oscillator with amplitude-independent period.

The next innovation, developed by Robert Hooke (1635-1703) and William Clement in 1671, was the anchor escapement in which a pendulum-driven escape arm alternately engaged gear teeth in the same plane (Fig. 3). This innovation permitted a smaller amplitude of oscillation for the pendulum, thus reducing the circular error. Clock accuracy was now reduced to 10 seconds per day. In addition, this design was more compact and allowed smaller and more affordable clocks to be built.

The anchor escapement is a mechanism that invites innovation. The earliest anchor escapements used an escape wheel, which turned primarily in one direction but recoiled slightly in the reverse direction after impact with the escape lever. George Graham (1673-1751) refined the geometry of the escape wheel and escape lever to eliminate this recoil, thereby inventing the deadbeat escapement. In modern technology, a deadbeat controller produces no overshoot in the closed-loop response.

The anchor escapement was further refined by John Harrison, a carpenter by trade, who built wooden clocks of fantastic precision, accurate to 1 second per month, which he verified by astronomical observation. The clocks he built benefited from his superb use of common and exotic woods and their self-lubricating properties. The ability to avoid lubricants is a critical feature, since lubricants available at that time could be broken down by bacteria. All of these features were incorporated in his grasshopper escapement, a precision mechanism whose escape lever consisted of delicate limbs, which touched the teeth of the escape wheel without sliding against the teeth. Harrison labored for 30 years to build clocks that held their accuracy of 1/3 second per day on rolling ships in hot and cold weather. With these accomplishments he vied for the lucrative prize offered by the British Government for determining longitude at sea. Although Harrison met the requirements for the prize, his award was blocked by astronomers who tried and failed to



develop alternative methods. Harrison was eventually awarded an equivalent sum from Parliament for his accomplishments.

Feedback plays a role in both the verge-and-foliot and pendulum clocks. The verge-and-foliot clock involves the interaction of two subsystems. The first system is composed of the verge and foliot, which has damped rigid-body motion; that is, it is semistable. Left alone, this subsystem would come to rest at an arbitrary orientation determined by its initial conditions and the frictional and viscous damping. The second system is the crown gear, which is also a damped rigid body, but is subject to constant torque input. Left alone, this subsystem would reach a terminal velocity. These two subsystems interact through collisions in terms of their angles and angular velocities. The period of oscillation of the closed-loop system is a consequence of their combined dynamics through feedback interaction.

For the pendulum-based clock, the interacting subsystems are the pendulum, which is asymptotically stable due to frictional and viscous damping, and the escape wheel, which is a damped rigid body with constant torque forcing. The period of oscillation of this clock is set largely, but not completely, by the period of oscillation of the pendulum. Since the pendulum is damped, however, it loses energy during each swing, and thus it must receive energy through the interaction of the escape wheel and the escape lever. This energy must be imparted to the pendulum in proper phase so as to increase the kinetic energy of the pendulum, much as an adult pushes a child on a swing. However, the angle of the pendulum cannot be predicted accurately over long time periods. Therefore, the escape wheel/escape lever interaction uses feedback to establish the proper phase for transferring energy. In addition, the amount of energy that needs to be imparted must exactly balance the energy lost due to damping. Since this amount cannot be set precisely, likewise, the amplitude of the pendulum cannot be set precisely. For small angles, however, the simple harmonic motion approximation of the pendulum motion is valid, and this provides robustness to the amplitude variation.

Besides its constantly improving accuracy, which soon surpassed sundials and water clocks, the mechanical clock had an innate advantage: it worked on cold and cloudy days. This ability was profound, since it allowed time to be measured independently of nature. The mechanical clock had no concern for lengths of days and nights, and it ignored the changes of season. With the measure of time now divorced from the variations of nature, time became a commodity that could be measured and sold in the service of labor and financial investment. Industries, governments, and armies could be coordinated, with tremendous political and economic advantage.

The mechanical clock allowed craftsmen to refine techniques of metalworking and mechanics. These skills and techniques ushered in a new age of technology that could be applied to industry. With the ability to measure time, mechani-

cal clock technology ushered in the Scientific Revolution and provided the basis for the Industrial Revolution.

Although the escapement was the key device at the heart of the mechanical clock, another device was briefly considered for the same purpose. Huygens designed a clock that used a conical pendulum instead of an escapement wheel. As the rotational speed increased, the centrifugal force on the pendulum increased, thereby causing the weight-driven torque applied to the clockwork to increase. Unlike the discrete jumps of the escapement, this device moved the clockwork smoothly.

Huygens' conical pendulum clock would have been a mere curiosity were it not for the next major phase of technology, which concerned the increasing power and availability of mechanical energy. While the source of energy was coal, the transformation of that energy into a mechanically useful form was performed by the steam engine. The steam engine in turn depended on a regulator for its controlled operation. That regulator, it turned out, was to rely not on the tick-tock of the clock escapement, but rather on the smooth speed regulation of Huygens' conical pendulum.

## The Governor

... this is produced by the centrifugal force of 2 lead weights which rise up horizontal when in motion and fall down when ye motion is decreased, by which means they act on a lever that is divided as 30 to 1, but to explain it requires a drawing.

— Matthew Boulton, in a letter to James Watt dated 28 May 1788, reporting on the centrifugal governor installed on a steam engine by John Rennie at the Albion Mills in London [Mayr, 1970, p. 110]

Energy is elusive. As the driving weight in a mechanical clock falls, its potential energy changes to kinetic energy. With similar ease, energy changes from chemical to electrical, electrical to thermal, and thermal to electromagnetic. We borrow energy as it passes through us. These simple but profound concepts eluded the best minds for centuries.

Work occurs only when energy is transferred. To multiply the work that humans can do, we use machines, and those machines require energy. Burning organic material provides a source of thermal energy, which was undoubtedly one of the earliest sources of energy to be exploited. The earliest machines were not powered by combustion, however; their source was the motion of water and wind.

As water flows downhill, its energy, like that of the clock weight, is converted from potential to kinetic. The engineers of ancient Rome captured some of that energy by building mills driven by waterwheels. These mills were used to grind grain. The largest Roman mill, located in Provence, France, operated 16 waterwheels and ground 28 tons of corn per day, enough to feed 80,000 people and equivalent to the combined effort of 1,000 slaves. During the middle ages, mills driven by waterwheels were

used to forge iron, full cloth, make paper, tan leather, and pump water. The economic and social impact of this technology was considerable.

The construction of waterwheels depended on gearing, which was made of wood until iron gearing became available in the 18th century. In medieval times, this knowledge was the province of millwrights, who were the forerunners of modern mechanical engineers. Millwrights were itinerant; they traveled from location to location, designing, constructing, and maintaining mills. Although their tools were rudimentary, their work was remarkably precise and innovative.

A river is a reliable source of energy. Barring droughts, floods, and freezing conditions, the flow of a river is constant over long periods of time. However, waterpower requires a suitable climate and topography, and when these conditions are not favorable, wind power provides an alternative source of energy.

## Governors

- D.M. Auslander, "The computer as liberator: The rise of mechanical system control," *Trans. ASME J. Dyn. Sys. Meas. Contr.*, vol. 115, pp. 234-238, 1993.
- C.T.G. Boucher, *John Rennie 1761-1821, The Life and Work of a Great Engineer*. Manchester, U.K.: Manchester Univ. Press, 1963.
- T.A. Edison, "Centrifugal speed governor," U.S. Patent 1,583,783.
- S. Freese, *Windmills and Millwrighting*. Cambridge, U.K.: Cambridge Univ. Press, 1971.
- A.T. Fuller, "Maxwell's treatment of governors fitted with differential gears," *Int. J. Contr.*, vol. 65, pp. 385-408, 1996.
- A.T. Fuller, "Maxwell's treatment of Siemens's hydraulic governor," *Int. J. Contr.*, vol. 60, pp. 861-884, 1994.
- R.L. Hills, *Power from Steam*. Cambridge, U.K.: Cambridge Univ. Press, 1989.
- R.L. Hills, *Power from Wind: A History of Windmill Technology*. Cambridge U.K.: Cambridge Univ. Press, 1994.
- B. Hindle and S. Lubar, *Engines of Change: The American Industrial Revolution 1790-1860*. Washington, D.C.: Smithsonian Institution Press, 1986.
- O. Mayr, *Feedback Mechanisms in the Historical Collections of the National Museum of History and Technology*. Washington, D.C.: Smithsonian Institution Press, 1971.
- O. Mayr, "Victorian physicists and speed regulation: An encounter between science and technology," *Notes and Records of the Roy. Soc. London*, vol. 26, pp. 205-228, 1971.
- O. Mayr, "James Clerk Maxwell and the origins of cybernetics," *Isis*, vol. 62, pp. 425-444, 1971.
- O. Mayr, "Yankee practice and engineering theory: Charles T. Porter and the dynamics of the high speed steam engine," *Technol. Culture*, vol. 16, pp. 570-602, 1975.
- M. Watts, "The rise of the governor," *Trans. Int. Molinological Soc.*, vol. 6, pp. 337-348, 1985.

The earliest windmills appeared in Persia in the seventh century, and their primary function was irrigation. These were horizontal windmills, which drove a vertical shaft. Much later, in the 12th century, vertical windmills appeared in Western Europe. Their use flourished: in the 13th century, there were 120 windmills operating in the vicinity of Ypres, Belgium.

Unlike waterpower, which is reliable, wind power is variable: its speed and direction are constantly shifting. Consequently, early windmills were built on a post, which allowed the entire mill to be turned into the wind. In the 15th century, millwrights refined this design so that only the mill's cap was turned. In both cases, these adjustments were made manually.

In a British patent application dated 1745, the variability of the wind in both speed and direction was addressed by the blacksmith Edmund Lee. To compensate for wind speed variations, he invented a mechanism that rotated the sails about their long axis. This device depended on a counterweight: the force of the wind itself rotated the blades. In addition, to compensate for wind direction, he proposed an auxiliary set of blades located behind the main blades (Fig. 4). This fantail mechanism turned the mill's cap automatically, thereby eliminating the need for manual changes in the mill's orientation. The fantail thus had the ability to follow the wind direction; any device having the ability to follow commands is a servomechanism.

Another problem was caused by the speed variation of the wind. The gap between the millstones tended to widen with increasing speed. Although more grain could be ground, it was necessary to increase the force between the stones. The lag governor accomplished this by means of two pendula whose bobs were constrained to swing tangentially to the circle of rotation. Neglecting air resistance, the angle of swing is proportional to angular acceleration. As the angles of the pendula increased, a rod connecting the pendula changed the force between the stones. An alternative device for controlling the force between the stones was the centrifugal governor, in which the weights swung outward (Fig. 5). Unlike the lag governor, the swing angle of the weights of the centrifugal governor is proportional to angular rate.

The centrifugal governor used to control the force between the millstones was not a feedback device for the simple reason that the speed of the windmill was not affected. To control the speed of the blades, Thomas Mead linked a centrifugal governor to a mechanism that furled and unfurled the windmill's sails. This feedback controller, which he patented in 1787, was a regulator, since it rejected disturbances (variations in wind speed) to maintain a desired blade speed.

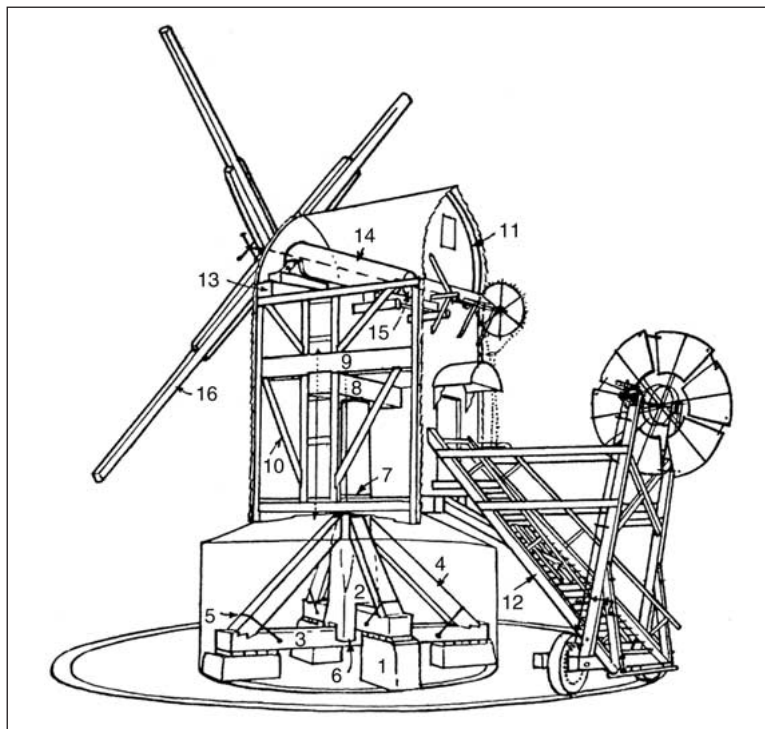
Meanwhile, in 1783, after 18 years of experimentation and development, the Scottish engineer James Watt (1736-1819) developed a practical steam engine that produced rotary motion. Watt's key development was an improved understand-

ing of thermodynamics; by introducing a separate, cold condenser, he obtained dramatic improvements in power and efficiency. To publicize his engine, Watt and his partner Matthew Boulton (1728-1809) contracted in 1784 to build a large corn mill in London. To oversee construction, they hired John Rennie (1761-1821), a meticulous millwright. Besides supervising the construction of the mill, Rennie introduced a key innovation: he adapted the centrifugal governor to regulate engine speed. Rennie's familiarity with centrifugal governors was due to the fact that he had trained for two years with one of Scotland's most famous millwrights, Andrew Meikle (1719-1811). Among Meikle's innovations, he improved Lee's method for adjusting the windmill's sails by replacing the counterweights with springs.

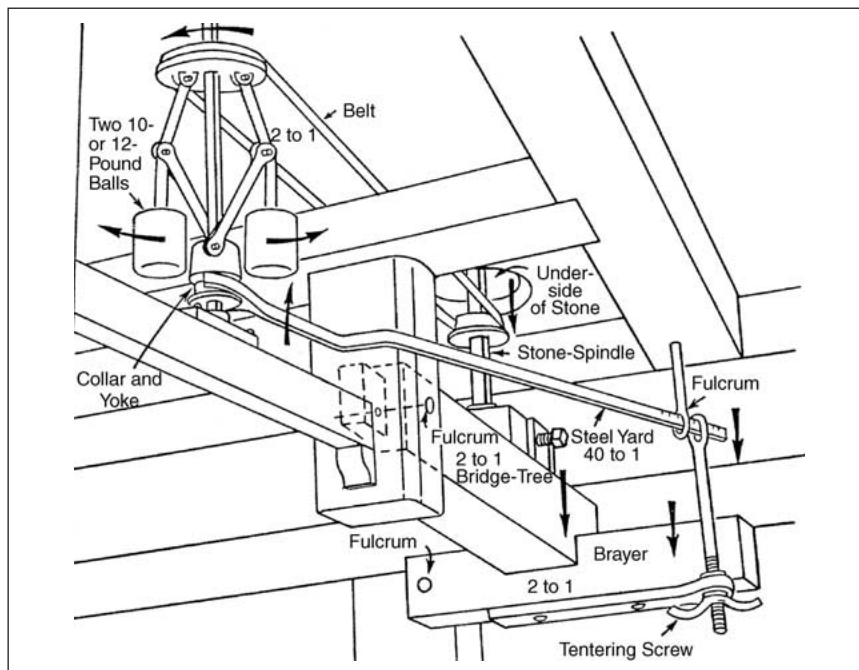
The centrifugal governor worked well with a lightweight throttle valve developed by Watt. The corn mill, while not a financial success, generated valuable publicity for Watt and Boulton in the competitive business of steam engines. Their business prospered.

The Watt governor represented a significant advance in technology, since it provided control over energy. The feedback loop allowed the steam engine to be self-regulating. Now the combustion of organic material could be used efficiently to do mechanical work. This ability to exploit large quantities of energy without being subject to the vagaries of the wind allowed machines to operate at power levels that were previously unattainable.

The governor itself became the subject of intense interest, both for its mysterious properties and its commercial value. The great scientists George Biddell Airy (1801-1892), Charles William Siemens (1823-1883), Leon Foucault (1819-1868), Lord Kelvin (William Thomson) (1824-1907), James Clerk Maxwell (1831-1879), and Josiah Willard Gibbs (1839-1903) were fascinated by its operation. They sought to improve on the shortcomings in its basic design, such as the lack of integral action (entailing steady-state offset), friction and saturation (causing repeated overshoot or hunting), and lack of power (limiting speed of response). These and other improvements were obtained by subsequent engineers; between 1836 and 1902, more than a thou-

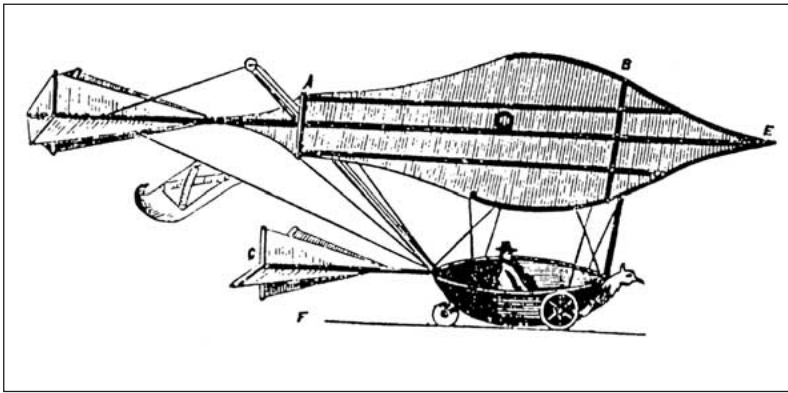


**Figure 4.** The fantail mechanism of a windmill was a conspicuous use of feedback. This auxiliary set of blades reacted to the direction of the wind to turn the windmill cap so that the main set of blades faced directly into the wind. ([Freese, 1971, p. 18], reprinted with the permission of Cambridge University Press.)



**Figure 5.** The centrifugal governor was used to regulate the force between the millstones. The spinning weights, which respond to centrifugal force, are connected to a series of linkages that increase the force between the stones at higher speeds. This is not a feedback mechanism, since there is no closed loop. However, a later patent by Mead used the centrifugal governor to furl and unfurl the cloth that covers the blades, thus using feedback to maintain a desired speed. ([Freese, 1971, p. 52], reprinted with the permission of Cambridge University Press.)





**Figure 6.** George Cayley's aircraft designs used aerodynamic surfaces for lift as well as stability. In 1853, he built a glider that successfully carried a person. ([Anderson, 2000, p. 11], reproduced with the permission of the McGraw-Hill Companies.)

sand patents were granted in the United States for governors.

The impact of the governor was immense, since every steam engine required one. In addition, the governor was used to regulate astronomical equipment, the telegraph, and the phonograph. In 1868, more than 75,000 governors were in use in England. Technological innovation was flourishing and the Industrial Revolution was under way. The steam engine powered factories, and it moved people and goods by means of railroad and ship. Although the steam engine was not suited to flight, feedback control, as we shall now see, was to prove crucial in air transportation.

## The Aileron

Not within a thousand years would man ever fly!

— Wilbur Wright, recalling in the 1940s his words spoken to his brother Orville in 1901 while departing Kitty Hawk for Dayton  
[Jakab, 1990, p. 114]

The secrets of powered flight are 1) thrust, 2) lift, 3) stability, and 4) control. The second of these, lift, is the use of aerodynamic forces to counteract gravity. The first successful human flight didn't use lift per se; rather, it exploited buoyancy. This achievement was the invention of the hot air balloon by Jean Michel Montgolfier (1740-1810) and his brother Jacques Etienne Montgolfier (1745-1799) in 1783. They flew over Paris to the amazement of onlookers. Hot air balloons proved to be useful in limited applications; for example, in the U.S. Civil War, they were used to spy on enemy troops.

Hot air balloons are stable; their dynamics are similar to those of a hanging pendulum. Unfortunately, balloons fail in the control category: unless tied down, they drift with the wind.

In 1853, George Cayley (1773-1857) was experimenting with gliders whose lift was due to aerodynamic surfaces. His gliders looked vaguely like modern aircraft (Fig. 6). In addition to the large aerodynamic surface for lift, Cayley in-

cluded an auxiliary pair of aerodynamic surfaces in the form of an aft structure to provide stability in pitch and yaw. These fixed aerodynamic surfaces played the same role as the horizontal and vertical tails on a modern aircraft.

Cayley's ideas were far ahead of their time. Although he published the results of his experiments, his work remained unknown to subsequent flight pioneers. Nevertheless, from 1889 to 1896, Otto Lilienthal (1848-1896) built and flew gliders. His gliders used fixed auxiliary aerodynamic surfaces for stability, and he was able to control the motion by shifting his weight. This knowledge came from extensive aerodynamic studies of lift and drag as well as experience: he built a symmetric hill from which he could glide regardless of the wind direction. Tragically, he died from injuries suffered when his glider stalled and crashed.

During the 19th century, there were numerous enthusiasts interested in the possibility of manned flight. Many ideas were sketched and few were built, of which fewer met with any success. Octave Chanute (1832-1910) collected an immense amount of information about these ideas and experiments. In 1894, he published this material in his book *Progress in Flying Machines*.

In 1899, the brothers Wilbur (1867-1912) and Orville Wright (1871-1948), who ran a bicycle shop in Dayton, OH, read Chanute's book. Two prophetic paragraphs can be found in the Conclusions section of Chanute's book. The first paragraph reads:

If a flying machine were only required to sail at one unvarying angle of incidence in calm air, the problem would be much easier of solution. The center of gravity would be so adjusted as to coincide with the center of pressure at the particular angle of flight desired, and the speed would be kept as regular as possible; but the flying machine, like the bird, must rise and must fall, and it must encounter whirls, eddies, and gusts from the wind. The bird meets these by constantly changing his center of gravity; he is an acrobat, and balances himself by instinct; but the problem is very much more difficult for an inanimate machine, and it requires an equipoise—automatic if possible—which shall be more stable than that of the bird.

Here Chanute makes an indisputable case for the importance of control. Stability is important, he asserts, but it is not enough; a flying machine must be able to maneuver, and it must be able to react to disturbances.

Earlier researchers realized this need. Drawings of (sometimes fanciful) aircraft from as early as the 1870s show a vertical rudder, presumably inspired by a ship's rudder. Other drawings show a horizontal rudder as well. Unlike the fixed auxiliary surfaces for stability, these surfaces were



movable, and they permitted control of the aircraft's motion. Thus, the importance of controlling motion about multiple axes of rotation was clearly recognized. The second paragraph from Chanute's book reads:

The guidance in a vertical direction—i.e., up or down, depends in a great degree upon success in changing the center of gravity which has just been alluded to. It may be partly effected by changes in the speed or by horizontal rudders, but in such case the equilibrium will be disturbed. Guidance in a horizontal direction has been secured, as we have seen in several experiments, by vertical rudders; but there are probably other methods still more effective, although their merits cannot be tested until a practical apparatus is experimented with. Upon the whole, this problem may give trouble, but it does not seem unsolvable.

Within five years of reading these very words, the Wrights demonstrated machine-powered manned flight. They accomplished this feat with a variety of evolutionary and revolutionary innovations. They adopted the biplane wing structure with truss supports developed by Chanute himself; they systematically developed a series of gliders with the aid of careful wind tunnel tests; they outfitted their gliders with movable aerodynamic surfaces for pitch and yaw control; for roll control, they invented wing warping, which was controlled jointly with the rudder for turning; they built powerful, lightweight engines and propellers; and, most importantly, they taught themselves to fly. They were self-supporting, and they had little outside assistance aside from correspondence with Chanute. In short, they combined the existing elements for powered flight, and they supplied the needed innovations.

The key innovation, which had no clear predecessor, was the use of wing warping to effect lateral control; that is, control for turning (Fig. 7). This innovation provided a full complement of movable aerodynamic surfaces to allow control over all three axes of rotational motion. This innovation was critical, since it made controlled flight possible.

Wing warping was an innovation that deserved protection. The Wrights patented the technique, which was based on the mechanical coupling of wing warping and vertical rudder deflection. Such coupling is needed when turning to counteract adverse yaw, an aerodynamic effect that would otherwise cause the airplane to sideslip (not point along its velocity vector) during turning. But the Wrights' patent was soon innovated. In 1908, Glenn Hammond Curtiss (1878-1930), a former motorcycle racer turned airplane manufacturer, was in direct competition with the Wrights. His technique for lateral control did not employ wing warping coupled with rudder deflection; rather, Curtiss used a pair of ailerons, which were operated as separate, movable aerodynamic surfaces. The idea of using movable aerodynamic surfaces for lateral control arose as early as 1904 in France for controlling a glider. In the United States, the idea was suggested in 1908 by Alexander Graham Bell

(1847-1922), who, at age 69, was an aviation enthusiast. He suggested the use of movable wing tips for lateral balance control. Casey Baldwin, an associate of Curtiss, implemented ailerons in the form of wing tips on Curtiss's White Wing aircraft, which he flew in May 1908. The pilot controlled the ailerons by means of a shoulder harness; by moving his body, the pilot effected lateral control. Only later was

## Ailerons

- M.J. Abzug and E.E. Larrabee, *Airplane Stability and Control: A History of the Technologies That Made Aviation Possible*. Cambridge, U.K.: Cambridge Univ. Press, 1997.
- J.D. Anderson, Jr., *A History of Aerodynamics*. Cambridge, U.K.: Cambridge Univ. Press, 1998.
- J.D. Anderson, *Introduction to Flight*, 4th ed. New York: McGraw-Hill, 2000.
- R.H. Barnard and D.R. Philpott, *Aircraft Flight*, 2nd ed. Essex, U.K.: Longman, 1995.
- W. Boyne, T. Gwynn-Jones, and V. Moolman, *Flight*. Alexandria, VA: Time-Life Books, 1990.
- R.V. Bruce, *Bell: Alexander Graham Bell and the Conquest of Solitude*. Ithaca, NY: Cornell Univ. Press, 1973.
- O. Chanute, *Progress in Flying Machines*. New York: Dover, 1997.
- T. Crouch, *The Bishop's Boys: A Life of the Wright Brothers*. New York: Norton, 1989.
- S. Dalton, *The Miracle of Flight*. Buffalo, NY: Firefly Press, 1999.
- M. Grosser, *Gossamer Odyssey: The Triumph of Human-Powered Flight*. New York: Dover, 1991.
- F. Howard, *Wilbur and Orville: A Biography of the Wright Brothers*. Mineola, NY: Dover, 1987.
- P.L. Jakab, *Visions of a Flying Machine: The Wright Brothers and the Process of Invention*. Washington, D.C.: Smithsonian Institution Press, 1990.
- F.G. Kelly, *The Wright Brothers*. New York: Dover, 1989.
- B.R. Rich and L. Janos, *Skunk Works*. Boston, MA: Little, Brown, 1994.
- C.R. Roseberry, *Glenn Curtiss: Pioneer of Flight*. Syracuse, NY: Syracuse Univ. Press, 1972.
- D. Stinton, *The Anatomy of the Airplane*, 2nd ed. Washington, D.C.: AIAA, 1998.
- J. Stoff, *Picture History of Early Aviation, 1903-1913*. New York: Dover, 1996.
- H. Tennekes, *The Simple Science of Flight: From Insects to Jumbo Jets*. Cambridge, MA: MIT Press, 1997.
- W.G. Vincenti, *What Engineers Know and How They Know It: Analytical Studies from Aeronautical History*. Baltimore, MD: Johns Hopkins Univ. Press, 1990.
- P.P. Wegener, *What Makes Airplanes Fly? History, Science and Applications of Aerodynamics*, 2nd ed. New York: Springer, 1997.
- O. Wright, *How We Invented the Airplane*. New York: Dover, 1953.
- C. Yeager and L. Janos, *Yeager*. New York: Bantam Books, 1985.

## The verge-and-foliot escapement measured time by packaging it into intervals, namely, the intervals between impacts.

one of the hands freed up for aileron control by using the feet to control the elevator. The word “aileron” derives from the French phrase for “little wings,” reflecting their first appearance in France. In his 1909 airplane the June Bug, Curtiss mounted the ailerons midway between the biplane wings (Fig. 8). The separation of lateral control from lift was now complete in both form and function.

The use of ailerons had two distinct advantages over the Wrights’ patent. First, the ailerons had the sole purpose of providing a moment for rolling the aircraft, and their implementation effectively separated lateral control from lift. Consequently, the main wings intended for lift no longer needed to be warped and therefore could be stiffened. And second, the ailerons were controlled separately from the rudder to allow independent control of all three axes.

In 1905, the Wrights began to use separate hand controls for wing warping and rudder. They did not protect this variation of their original patent on coupled wing warping and rudder control. Although Curtiss used separate three-axis controls, the Wrights sued him for infringement of their patent on coupled rudder and wing warping. In the court’s view, Curtiss’s system for independent three-axis control infringed on the Wrights’ patent, since coupling of lateral and yaw control is nevertheless essential for turning.

Three-axis rotational control of the aircraft was now complete, and it depended on a complement of movable control surfaces, namely, the elevator, the rudder, and the ailerons. This technology also completed the essential elements of flight: thrust, lift, stability, and control. The Age of Aviation had been ushered in, and transportation and warfare were changed forever. The next step was to develop devices to assist the pilot in controlling the aircraft, as well as the means

to venture into space. To do this required yet another innovation—the gyro.

### The Gyro

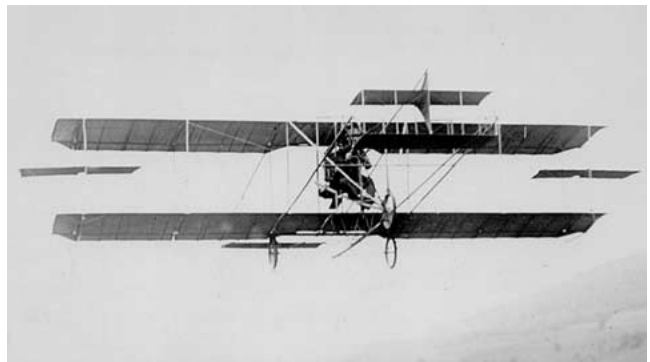
... if there were no other immortality, you would live forever in that achievement.

— Helen Keller, in a letter to Elmer Sperry dated 27 February 1930, after a tour of the Sperry Gyroscope Company [Hughes, 1971, p. 321]

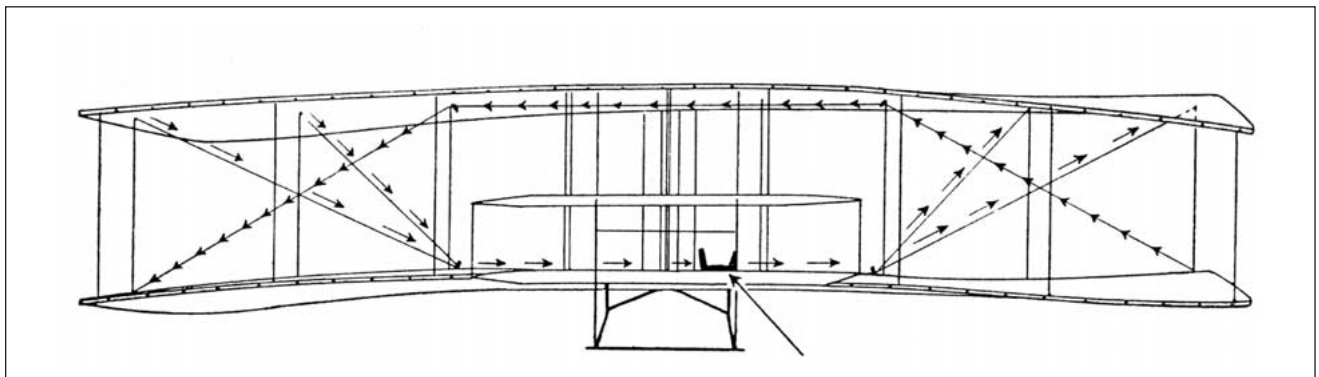
I saw a flock of birds lifting and wheeling in formation as they flew alongside the train. Suddenly I saw them as “devices” with excellent vision and extraordinary maneuverability. Could they not guide a missile? Was the answer to the problem waiting for me in my own backyard?”

— B.F. Skinner, describing his inspiration in 1940 for using pigeons for missile guidance [Capshew, 1993, p. 840]

On 18 June 1914, 21-year-old Lawrence Sperry (1893-1924) from Brooklyn, NY, piloted a Curtiss flying machine near Paris in a competition to demonstrate new technology for making flying safer. The aircraft carried Sperry and his French me-



**Figure 8.** In 1908, Glenn Curtiss flew his Gold Bug airplane, which used ailerons mounted between the biplane wings to effect lateral control. This innovation separated lateral control from lift, but was close enough in spirit to wing warping to entail a bitter patent battle with the Wrights. (Courtesy of the Smithsonian National Air and Space Museum.)



**Figure 7.** The Wrights’ key invention was the use of wing warping to effect lateral control. This innovation provided a full complement of movable aerodynamic surfaces to allow control over all three axes of rotational motion. ([Wright, 1953, p. 14], reproduced by permission.)

## Gyros

- J. H. Capshew, "Engineering behavior: Project Pigeon, World War II, and the conditioning of B.F. Skinner," *Technol. Culture*, vol. 34, pp. 835-857, 1993.
- P.E. Ceruzzi, *Beyond the Limits: Flight Enters the Computer Age*. Cambridge, MA: MIT Press, 1989.
- R.F. Deimel, *Mechanics of the Gyroscope: The Dynamics of Rotation*. New York: Macmillan, 1929. Reprinted by New York: Dover, 1950.
- E.S. Ferry, *Applied Gyrodynamics*. New York: Wiley, 1932.
- G. Greenhill, *Gyroscopic Theory*. Bronx, NY: Chelsea, 1966.
- T.P. Hughes, *Elmer Sperry: Inventor and Engineer*. Baltimore, MD: Johns Hopkins Univ. Press, 1971.
- C. Machover, *Basics of Gyroscopes*. New York: Rider, 1960.
- D. Mackenzie, *Inventing Accuracy: A Historical Sociology of Nuclear Missile Guidance*. Cambridge, MA: MIT Press, 1990.
- S. Merhav, *Aerospace Sensor Systems and Applications*. New York: Springer, 1996.
- J. Perry, *Spinning Tops and Gyroscopic Motion*. New York: Dover, 1957.
- K.I.T. Richardson, *The Gyroscope Applied*. New York: The Philosophical Library, 1954.
- P.H. Savet, Ed., *Gyroscopes: Theory and Design*. New York: McGraw-Hill, 1961.
- J.B. Scarborough, *The Gyroscope, Theory and Applications*. New York: Interscience, 1958.
- W.T. Thomson, *Introduction to Space Dynamics*. New York: Dover, 1961.
- J. Walker, *Roundabout: The Physics of Rotation in the Everyday World*. New York: Freeman, 1985.

chanic, Emile Cachin. In full view of the judges, Sperry stood up and placed his hands over his head. Cachin then stood up as well and proceeded to walk six feet onto the lower wing. Observers expected the plane to roll; instead, they saw the ailerons move automatically to maintain level flight (Fig. 9). They had witnessed the all-time most dramatic demonstration of a feedback control system, as well as a new era in flight.

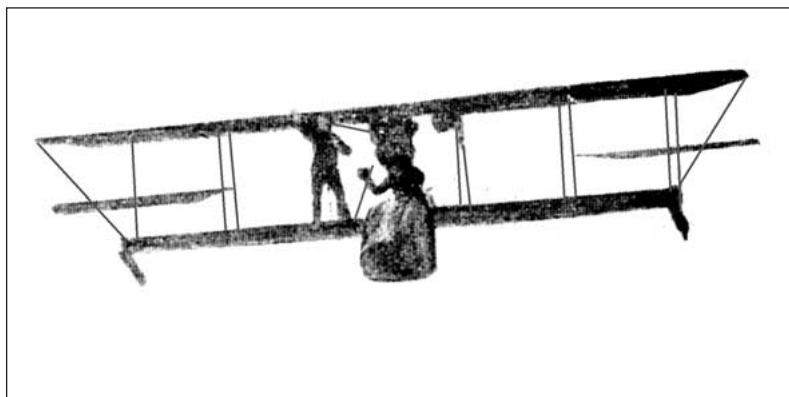
The key to this success was the practical implementation of a displacement gyroscope, or gyro, which is a spinning wheel mounted on gimbals. The gyro had been developed by Lawrence's father Elmer Ambrose Sperry (1860-1930). The spin axis of the wheel maintains its orientation in space as the gimbals rotate around it (Fig. 10). For flight control, the outer gimbal can be aligned with the roll axis, and the inner gimbal can be aligned with the pitch axis. When disturbances cause the plane to rotate, the gimbal angles provide measurements of the roll and pitch angles of the airplane.

In the system demonstrated in Paris, the gyro was connected to an electrical contact that closed a circuit when the airplane moved out of trim level flight. The electrical contact powered a valve that released compressed air supplied by the engine. The force of this compressed air moved the elevator and ailerons to bring the airplane back to level flight. In this way, Curtiss's ailerons and Sperry's gyro formed a feedback loop to stabilize the airplane's motion.

Aircraft stabilization was not the first application of the gyro, although it was the most important up to that time. Previously, Elmer Sperry and others had developed gyros for stabilizing automobiles and ships. In these applications, gyros were used for actuation as well as for sensing. The actuation was effected by a heavy flywheel that helped suppress roll motion. Although the automotive application was unsuccessful, the marine application met with good success on naval vessels and ocean liners.

An alternative use of a gyro comes in the form of a rate gyro, which determines the angular velocity about a given axis. A spinning wheel mounted on a single gimbal exerts a torque about an axis that is perpendicular to the rotation axis. For example, when the base of the gimbal rolls, the gyro pitches. This right-angle motion, called precession, is a consequence of the fact that applied torque induces a change in angular momentum. This torque can be measured by restraining the gimbal with a spring and measuring the resulting gimbal angle (Fig. 11).

The development of the gyro for determining angular displacement and angular rates created the ability to perform inertial navigation. Inertial navigation refers to navigation without using external signals such as radio beacons, magnetic compasses, or optical sightings. Gyrocompasses provide the means to determine heading, while the signals from rate gyros and accelerometers can be numerically integrated to determine location. These devices were essential to the development of missile guidance, submarine navigation, and space navigation technology. In addition, feedback control loops based on gyros have been used in autopilots



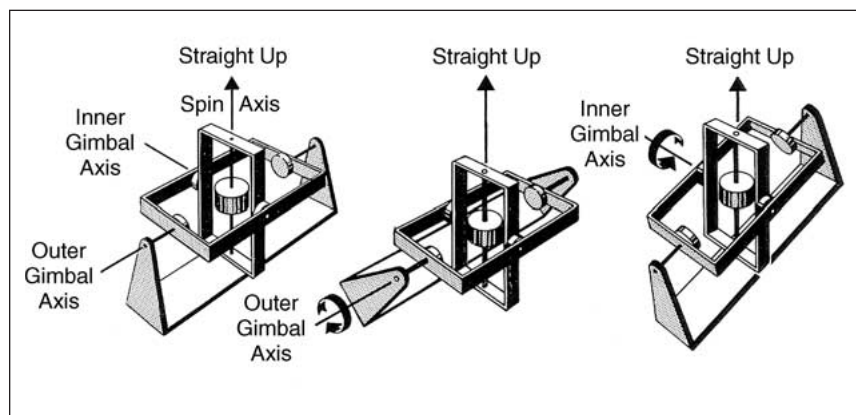
**Figure 9.** In the first public demonstration of gyroscopic stabilization, Lawrence Sperry, son of engineer Elmer Sperry, removes his hands from the controls while his mechanic, Emile Chardin, walks onto the lower wing. This demonstration occurred near Paris during a 1914 competition on innovative aircraft safety features [Hughes, 1971].



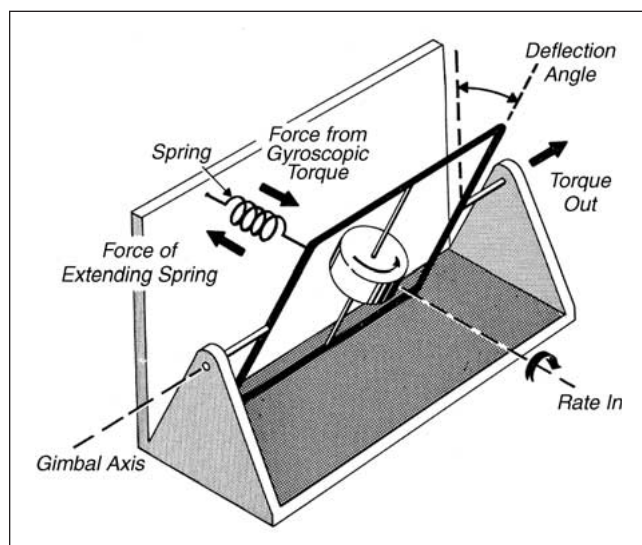
for pilot assistance or fully autonomous operation. In short, the gyro opened the door to the Space Age.

## The Amplifier

The control technology discussed thus far has been almost entirely mechanical: the escapement of a clock, the centrifugal governor of a windmill or steam engine, the aileron of an airplane, and the gyro of an aircraft stabilization system. Each of these inventions had a critical effect on the history of technology. And yet, perhaps the most significant application of feedback control was still to come. As we shall see, there were two distinct developments that shaped the Age of Electronics: the positive-feedback amplifier and the negative-feedback amplifier.



**Figure 10.** A displacement gyro is a spinning wheel mounted on a pair of gimbals. The spin axis of the wheel maintains its orientation in space as the gimbals rotate. By aligning the outer gimbal with the roll axis and the inner gimbal with the pitch axis, it is possible to measure these angles during flight. ([Machover, 1960, p. 1-3], reproduced by permission.)



**Figure 11.** A rate gyro uses precession to measure angular rate about a desired axis. By aligning the gimbal axis with the roll axis, a pitch rotation rate will produce a torque on the gimbal. This torque can be measured by restraining the gimbal by a spring and measuring the gimbal angle. ([Machover, 1960, p. 2-2], reproduced by permission.)

To begin, let us clarify that the amplifier is not inherently a feedback device. In fact, an amplifier is any device that takes an input signal of small amplitude and produces an output signal identical to the input signal but with larger amplitude. By itself, this is not a surprising feat; a lever placed asymmetrically with respect to a fulcrum is an amplifier. Any movement of the shorter end of the lever will be reproduced by the longer end with a larger amplitude of motion. The lever amplifies the arc length of the motion as well as its speed. Similarly, any input force applied to the longer end of the lever will produce an output force of greater magnitude at the shorter end. Thus, a lever can be used to amplify displacement, speed, or force.

Although an amplifier is not inherently a feedback device, it is an essential component of a feedback control system. The sensor measurements and error signals, which are generally small-amplitude, low-power signals, must ultimately drive actuators that require large power. In the millstone force control system of a windmill, amplification of the centrifugal-to-millstone force is provided by a series of levers. Similarly, Elmer Sperry's aircraft stabilizer used a pneumatic amplifier in which small angular displacements of the gyro gimbals modulated a valve, which released compressed air, and thereby produced large forces for moving the aerodynamic surfaces.

Electrification allowed engineers to operate electrical motors and lighting, but these developments did not depend on amplifiers. However, engineers were also concerned with the transmission of information, specifically, communication by telephone and radio. These technologies required amplifiers since the signals were weak and their waveform is of paramount importance. As we shall now discuss, it was feedback control that was essential to critical developments in each case.

## The Positive Feedback Amplifier

1113149

— The number of Armstrong's U.S. patent for the positive feedback amplifier, as emblazoned on a flag flown from the aerial tower above his mother's home in Yonkers, NY, and visible on clear days as far as the Bronx, where Lee de Forest lived [Lewis, 1991, p. 196]

While experimenting with lamps in 1880, Thomas Alva Edison (1847-1931) observed that a current could flow through a vacuum to a metal plate. He had no explanation for this phenomenon, called the Edison effect. In fact, only the discovery of the electron would provide a meaningful

explanation. Nevertheless, John Ambrose Fleming (1849-1945) studied the Edison effect while employed by the Edison Company in London. There was no immediate application of these studies.

The Edison effect proved to be but one, albeit crucial, step in the development of radio. The development of the radio went through many phases, from the electromagnetic theories of Maxwell (analyzer of the centrifugal governor) to the spark gap transmitters and receivers of Heinrich Hertz (1857-1894) to the frequency-selective circuits of Oliver Lodge (1851-1940) to the pulsating spark gap of Guglielmo Marconi (1874-1937). Like all great inventions, the development of the radio required a long chain of brilliant inventors and scientists. Marconi's advances, partly achieved by adapting the discoveries of the great scientists and partly by the accidental discovery of the benefits of grounding, enabled long-distance wireless telegraphy and became the basis of a new industry. He patented these inventions in 1896 when he was 22.

In 1904, Fleming was employed by the Marconi Company, and he returned to his studies of the Edison effect. He made a surprising discovery: an evacuated tube with a filament and plate had the ability to rectify ac radio waves. More than a mere curiosity, his diode-rectified telegraph signals could be heard through headphones. However, since the Marconi Company was interested in crystal diodes, they did not pursue the development of the tube diode.

Lee de Forest (1873-1961), a young engineer, read of Fleming's work and began experimenting with tubes. Like his predecessors, he did not understand their operation. But he made a momentous advance: by including a third wire (the grid) between the filament and plate, he was able to control and amplify the signal applied to the grid. The electronic amplifier was born.

Like all new inventions, this electronic amplifier had limited performance (low gain), and it was not well understood. Such was the case when Edwin Howard Armstrong (1890-1954) was an undergraduate at Columbia University, where he had access to test equipment and triode tubes. Armstrong had been an avid radio hobbyist, and he had considerable experience with radio circuits. He experimented extensively with the triode tube and, in 1912, built a triode-based amplifier circuit that had amazingly better performance characteristics than existing amplifiers.

The key to Armstrong's invention was the use of positive feedback, which he called regeneration. By feeding the audio signal back to the grid, he was able to boost the amplification of the triode circuit. In effect, the circuit reduced the damping of the oscillations. The amplification was over a narrow band of frequencies, but this was sufficient for radio applications.

Armstrong's circuit was extremely valuable. Several inventors around the world had developed similar circuits, but there was only a single challenger to his patent: de Forest. Years prior, de Forest had experimented with a circuit

that "howled." He had virtually no understanding of the circuit, and he failed to pursue it. Yet his challenge set in motion what is perhaps the most bitterly contested and lengthy patent litigation case in history. The Wright-Curtiss litigation paled by comparison. The de Forest-Armstrong regeneration case lasted almost 20 years, and, amazingly, it was decided by the Supreme Court not once, but twice (1928 and 1934). Armstrong lost both times. Nevertheless, the IRE (Institute of Radio Engineers and forerunner of IEEE) awarded Armstrong the Medal of Honor for what his fellow engineers recognized as truly his invention.

## The Positive-Feedback Amplifier

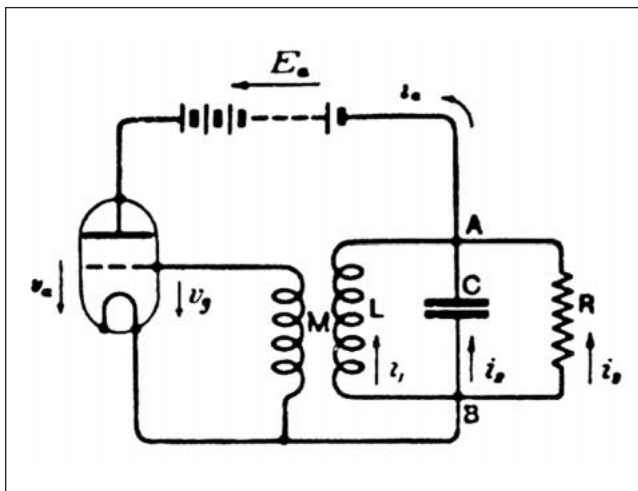
- H.G.J. Aitken, *Syntony and Spark: The Origins of Radio*. New York: Wiley, 1976.
- H.G.J. Aitken, *The Continuous Wave: Technology and American Radio, 1900-1932*. Princeton, NJ: Princeton Univ. Press, 1985.
- H. Bremmer and C.J. Bouwkamp, *Balthasar van der Pol: Selected Scientific Papers*. Amsterdam, Holland: North-Holland, 1960.
- J.E. Brittain, *Alexanderson*. Baltimore, MD: Johns Hopkins Univ. Press, 1992.
- J.Z. Buchwald, *The Creation of Scientific Effects: Heinrich Hertz and Electric Waves*. Chicago, IL: Univ. of Chicago Press, 1994.
- R. Conot, *Thomas A. Edison: A Streak of Luck*. New York: Seaview, 1979. Reprinted by New York: Da Capo Press, 1986.
- S.J. Douglas, *Inventing American Broadcasting 1899-1922*. Baltimore, MD: Johns Hopkins Univ. Press, 1987.
- P. Israel, *Edison: A Life of Invention*. New York: Wiley, 1998.
- J. Jespersen and J. Fitz-Randolph, *From Sundials to Atomic Clocks: Understanding Time and Frequency*, 2nd ed. Mineola, NY: Dover, 1999.
- R.R. Kline, *Steinmetz: Engineer and Socialist*. Baltimore, MD: Johns Hopkins Univ. Press, 1992.
- L. Lessing, *Man of High Fidelity: Edwin Howard Armstrong*. New York: Bantam, 1969.
- T.S.W. Lewis, *Empire of the Air: The Men Who Made Radio*. New York: HarperCollins, 1991.
- D. Marconi, *My Father, Marconi*. Toronto: Guernica, 1996.
- P.J. Nahin, *The Science of Radio*. Woodbury, NY: American Institute of Physics, 1996.
- J.M. Thomas, *Michael Faraday and the Royal Institution: The Genius of Man and Place*. Bristol, U.K.: Adam Hilger, 1991.
- D.G. Tucker, "The history of positive feedback: The oscillating audion, the regenerative receiver, and other applications up to around 1923," *Radio and Electron. Engin.*, vol. 42, no. 2, pp. 69-80, 1972.
- B. van der Pol, "A theory of the amplitude of free and forced triode vibrations," *Radio Rev.*, vol. 1, pp. 701-762, Nov. 1920.

While the ability to produce high gain was the major benefit of his circuit, Armstrong found that the positive feedback amplifier offered yet another feature that was critical to the development of radio. If the gain of the amplifier is sufficiently increased, the circuit oscillates stably; that is, the oscillations can be produced indefinitely without increasing or decreasing in amplitude and with constant frequency. The ability to produce stable oscillations is not a mere curiosity; rather, it is a necessary component for modulating and demodulating signals.

The ability to transmit voice and music depended on high-frequency radio communication. One approach to the requisite modulation for transmission was the development of a generator by Ernst Alexanderson (1878-1975), who worked with Charles Proteus Steinmetz (1865-1923) at GE. The Alexanderson generator weighed many tons, and its spinning disk alone was massive. Yet this machine succeeded in producing the first broadcast of voice and music. The date was Christmas Eve, 1906. However, the positive-feedback amplifier rendered the Alexanderson generator obsolete; an electronic feedback circuit replaced a massive machine.

The stable oscillations produced by a triode circuit with high-gain positive feedback were later understood to be a result of the nonlinear characteristic of the triode tube. The nonlinear analysis, which was performed by Balthasar van der Pol (1889-1959) (Fig. 12), stands as a classic in nonlinear dynamics.

Although many radio circuits had been proposed for demodulating signals, Armstrong's circuit, the superheterodyne, was by far the most successful. This circuit, dating from 1917, incorporated an oscillator for signal demodulation at a frequency located a fixed distance from the incoming signal. The demodulation circuit took a high-frequency signal and produced a low-frequency signal that could be



**Figure 12.** This positive-feedback circuit with the transformer output connected to the triode grid produces sustained oscillations that can be used for radio signal modulation and demodulation. The governing equation is known as the van der Pol oscillator [van der Pol, 1920].

easily filtered and amplified. This circuit survived the transition from vacuum tubes to silicon chips.

## The Negative Feedback Amplifier

Black requested permission to work on amplifier design which was granted on the condition that it did not interfere with his other work.

— [Bennett, 1993, p. 73]

By 1911, it was possible to place a long-distance call from Boston to Denver; however, there were serious problems with distortion. Only after amplifier technology improved in the 1930s was long-distance telephone communication truly feasible. The solution to the distortion problem that would improve amplifier technology was as radical as it was classical. Harold Stephen Black (1898-1983), an electrical engineer employed by American Telephone and Telegraph, wrestled with the problem for a long time. He was especially influenced by a lecture given by Steinmetz in 1923, where Steinmetz encouraged problem solving based on fundamental principles.

Black realized that he could solve the distortion problem if he could amplify signals with precise gain. Subtracting the suitably scaled (but distorted) output of an amplifier from the input would reveal the distortion; amplifying the distortion and subtracting it from the output would leave an undistorted signal. The concept was simple, but it would only work with precise amplifiers. Attempts to set the amplifier gain were invariably useless: drift could occur in a matter of hours. On his way to work one Saturday morning in 1927, as he crossed the Hudson River on a ferry, the key idea occurred to him: Use negative feedback to set the gain at a precise, albeit lower, value.

The basis of Black's circuit was this: Let  $G$  denote the open-loop gain of an amplifier, and let  $k$  denote the feedback gain. Then the closed-loop gain  $\tilde{G}$  is given by

$$\tilde{G} = \frac{G}{1 + kG}. \quad (1)$$

When  $kG$  is much larger than one, this yields

$$\tilde{G} \approx \frac{1}{k}, \quad (2)$$

a precise value in spite of uncertainty and drift in  $G$ . But making  $kG$  much larger than one makes  $1/k$  much less than  $G$ . Therefore, this circuit uses negative feedback to reduce the amplifier gain. Fortunately, this reduction was not an obstacle, since amplifiers could be built with extremely large (but usually imprecise) gain.

As simple as this idea was, the patent office treated it with skepticism; nine years passed from patent application to granting. On the practical side was the psychological resistance to purposefully lowering the gain of an amplifier. On the mathematical side, there were questions about stability. It was difficult to understand how stability could hold



when the loop gain  $kG$  was greater than unity; in fact, it was well known that oscillations occurred in high-gain, positive-feedback amplifiers. It fell to Harry Nyquist (1889-1976) to develop a stability theory that accounted for the frequency-dependent gain and phase of a transfer function (at least for stable loop transfer functions; the case of an unstable loop transfer function was resolved later). Hendrik Wade Bode (1905-1982) elucidated the subtleties of amplifier design (limitations and tradeoffs) in subsequent classical research. Ironically, the centrifugal governor and gyro stabilizer had been used for years in negative feedback loops; however, before the work of Nyquist and Bode, there was little theoretical understanding of the frequency-domain ramifications of stability.

AT&T recognized the value of the idea. Working models were built to convince the patent office, and the awarded patent had an astounding 126 claims.

The negative feedback amplifier had implications well beyond long-distance telephone communication. William R. Hewlett (1913-2001) studied applications of negative feedback as a graduate student at Stanford University. Working with David Packard (1912-1996) in a garage in Palo Alto, Hewlett developed an audio oscillating device for testing sound equipment. Walt Disney Studios used eight of the devices when they developed the soundtrack for *Fantasia*. The garage in which Hewlett and Packard worked became a California state historical landmark, recognized as the birth-

place of Silicon Valley. An official plaque provides a tribute to the impact of feedback control on modern technology:

BIRTHPLACE OF "SILICON VALLEY" This garage is the birthplace of the world's first high-technology region, "Silicon Valley." The idea for such a region originated with Dr. Frederick Terman, a Stanford University pro-

## The governor itself became the subject of intense interest, both for its mysterious properties and its commercial value.

fessor who encouraged his students to start up their own electronics companies in the area instead of joining established firms in the East. The first two students to follow his advice were William R. Hewlett and David Packard, who in 1938 began developing their first product, an audio oscillator, in this garage. California registered historical landmark no. 976.

### Conclusions

Is feedback control merely a footnote in the history of technology? In this article, I have attempted to suggest otherwise. The mechanical clock was the most precise and sophisticated machine of its time; its development had a profound impact on society, and it helped usher in the Scientific Revolution. Although the centrifugal governor was a convenience for operating a windmill, it was a crucial component of the steam engine and hence of the Industrial Revolution.

The aileron completed the requirements for controlled flight, and it helped to usher in the Age of Aviation. Likewise, the gyro was a crucial component needed for guidance and control in the Space Age.

The Electronic Revolution owed much to feedback control. The positive-feedback amplifier provided increased gain as well as a stable oscillator for modulation and demodulation, essential components of radio frequency circuits. The negative-feedback amplifier provided the means to build precision amplifiers with low distortion. The "trick" of using negative feedback to increase the precision of an inherently imprecise device was subtle and brilliant, and it was precisely this idea that had made the steam engine practical and rendered the mechanical clock "better" than its individual parts.

The fact that the invisible technology of feedback control has had such a profound impact on the history of technology should not be especially surprising. Feedback control has the ability to combine components into larger, more complex systems with higher precision. An open-loop clock would be unthinkable.

Finally, what does the history of control engineering augur for the future of technology? When the next great wave

### The Negative-Feedback Amplifier

H.S. Black, "Stabilized feed-back amplifiers," *Elect. Eng.*, vol. 53, no. 1, pp. 114-120, 1934. Reprinted in *Proc. IEEE*, vol. 87, pp. 379-385, Feb. 1999.

H.S. Black, "Stabilized feedback amplifiers," *Bell Sys. Tech. J.*, vol. 13, no. 3, pp. 1-18, 1934.

H.S. Black, "Inventing the negative feedback amplifier," *IEEE Spectr.*, pp. 54-60, Dec. 1977.

H.W. Bode, "Obituary statement: Harry Nyquist," *IEEE Trans. Automat. Contr.*, vol. AC-22, pp. 897-898, Dec. 1977.

H.W. Bode, "Relations between attenuation and phase in feedback amplifier design," *Bell Sys. Tech. J.*, vol. 19, no. 3, pp. 421-446, 1940.

B. Friedland, "Introduction to 'Stabilized feed-back amplifiers,'" *Proc. IEEE*, vol. 87, pp. 376-378, Feb. 1999.

P.J. Nahin, *Oliver Heaviside, Sage in Solitude*. New York: IEEE Press, 1988.

M.E. Van Valkenburg, "In memoriam: Hendrik W. Bode," *IEEE Trans. Automat. Contr.*, vol. AC-29, pp. 193-194, Mar. 1984.

I. Yavetz, *From Obscurity to Enigma: The Work of Oliver Heaviside, 1872-1889*. Basel, Switzerland: Birkhauser, 1995.

of technology washes over civilization (nano/bio/quantum/...), feedback control will surely lie at its heart.

## Acknowledgments

This article is based on an invited talk I presented at the First NSF Workshop on Ideas and Technology of Control and Systems in High School Math and Science Education, 27 June 2000, Chicago, IL. I am indebted to Prof. B. Pasik-Duncan for the invitation. I also wish to thank Mark Headrick for numerous helpful discussions, Susan Kolovson for encouragement, and Scot and Tammy Osburn for helpful comments. I dedicate this article to my mother, Shorrie Bernstein.

## Bibliography

### History of Technology and Engineering

- G. Basalla, *The Evolution of Technology*. Cambridge, U.K.: Cambridge Univ. Press, 1988.
- D.P. Billington, *The Innovators: The Engineering Pioneers Who Made America Modern*. New York: Wiley, 1996.
- R. Burlingame, *Scientists Behind the Inventors*. New York: Avon, 1960.
- J. Brockman, Ed., *The Greatest Inventions of the Past 2,000 Years*. New York: Simon & Schuster, 2000.
- D. Cardwell, *Wheels, Clocks, and Rockets: A History of Technology*. New York: Norton, 2001.
- C.M. Cipolla, *Guns, Sails, and Empires: Technological Innovation and the Early Phases of European Expansion 1400-1700*. Manhattan, KS: Sunflower Univ. Press, 1985.
- M. Cocker, *Rivers of Blood, Rivers of Gold: Europe's Conquest of Indigenous Peoples*. New York: Grove Press, 1998.
- T.K. Derry and T.I. Williams, *A Short History of Technology from the Earliest Times to A.D. 1900*. Oxford: Oxford Univ. Press, 1961. Reprinted by New York: Dover, 1993.
- J. Diamond, *Guns, Germs, and Steel: The Fates of Human Societies*. New York: Norton, 1997.
- E.S. Ferguson, *Engineering and the Mind's Eye*. Cambridge, MA: MIT Press, 1994.
- F. Gies and J. Gies, *Cathedral, Forge, and Waterwheel: Technology and Invention in the Middle Ages*. New York: HarperCollins, 1995.
- D.R. Headrick, *The Tools of Empire*. New York: Oxford Univ. Press, 1981.
- D. Hill, *A History of Engineering in Classical and Medieval Times*. London: Routledge, 1996.
- E.J. Hobsbawm, *Industry and Empire: From 1750 to the Present Day*. New York: The New Press, 1999.
- K.S. Kirby, S. Withington, A.B. Darling, and F.G. Kilgour, *Engineering in History*. New York: McGraw-Hill, 1956. Reprinted by New York: Dover, 1990.
- W.H. McNeill, *The Pursuit of Power*. Chicago: Univ. of Chicago Press, 1982.
- J. Mokyr, *The Lever of Riches: Technological Creativity and Economic Progress*. New York: Oxford Univ. Press, 1990.
- L. Mumford, *Technics and Civilization*. San Diego, CA: Harcourt Brace, 1963.
- L. Mumford, *The Myth and the Machine: I Technics and Human Development*. San Diego, CA: Harcourt Brace, 1967.

- L. Mumford, *The Myth and the Machine: II The Pentagon of Power*. San Diego, CA: Harcourt Brace, 1970.
- A.W.J.G. Ord-Hume, *Perpetual Motion: The History of an Obsession*. New York: St. Martin's Press, 1977.
- C. Pursell, *The Machine in America: A Social History of Technology*. Baltimore, MD: Johns Hopkins Univ. Press, 1995.
- D.L. Spar, *Ruling the Waves*. New York: Harcourt, 2001.
- A.P. Usher, *A History of Mechanical Inventions*, rev. ed. Cambridge, MA: Harvard Univ. Press, 1954. Reprinted by New York: Dover, 1988.
- S. Vogel, *Cats' Paws and Catapults: Mechanical Worlds of Nature and People*. New York: Norton, 1998.
- N. Wiener, *Invention: The Care and Feeding of Ideas*. Cambridge, MA: MIT Press, 1994.

### History of Control Engineering

- B.D.O. Anderson, "Control engineering as an integrating discipline from the 17th to the 21st century," *Int. J. Soc. Mat. Eng. for Resources*, vol. 1, pp. 10-26, 1991.
- D.M. Auslander, "Evolutions in automatic control," *Trans. ASME J. Dyn. Sys. Meas. Contr.*, vol. 93, pp. 4-9, 1971.
- R. Bellman, *Eye of the Hurricane: An Autobiography*. Singapore: World Scientific, 1984.
- S. Bennett, *A History of Control Engineering 1800-1930*. London: Peregrinus, 1979.
- S. Bennett, *A History of Control Engineering 1930-1955*. London: Peregrinus, 1993.
- Editors of *Scientific American, Automatic Control*. New York: Simon and Schuster, 1955.
- A.T. Fuller, "The early development of control theory," *ASME J. Dyn. Sys. Meas. Contr.*, vol. 98, pp. 109-118, June 1976.
- A.T. Fuller, "The early development of control theory II," *ASME J. Dyn. Sys. Meas. Contr.*, vol. 98, pp. 224-235, Sept. 1976.
- K. Kelly, *Out of Control*. Reading, MA: Addison-Wesley, 1994.
- L. Maunder, *Machines in Motion*. Cambridge, U.K.: Cambridge Univ. Press, 1986.
- O. Mayr, *The Origins of Feedback Control*. Cambridge, MA: MIT Press, 1970.
- O. Mayr, *Authority, Liberty, and Automatic Machinery in Early Modern Europe*. Baltimore, MD: Johns Hopkins Univ. Press, 1986.
- N. Wiener, *Cybernetics: Or Control and Communication in the Animal and the Machine*, 2nd ed. Cambridge, MA: MIT Press, 1961.
- N. Wiener, *The Human Use of Human Beings: Cybernetics and Society*. Boston, MA: Houghton Mifflin, 1954; reprinted by New York: Da Capo Press, 1988.

**Dennis S. Bernstein** received his Ph.D. degree from the University of Michigan in 1982, where he is currently a faculty member in the Aerospace Engineering Department. Previously, he was employed by Lincoln Laboratory and Harris Corporation. He has held adjunct and visiting positions at FIT, MIT, the University of Leeds, and the University of Glasgow. His theoretical interests are currently in the areas of identification and adaptive control with application to noise, vibration, and motion control. He is a frequent contributor to *IEEE Control Systems Magazine* and was a plenary speaker at the 2001 Conference on Decision and Control.