



Robotics 1

Industrial Robotics

Prof. Alessandro De Luca

DIPARTIMENTO DI INGEGNERIA INFORMATICA
AUTOMATICA E GESTIONALE ANTONIO RUBERTI



SAPIENZA
UNIVERSITÀ DI ROMA



What is a robot?

- *industrial* definition (RIA = Robotic Institute of America)

re-programmable multi-functional manipulator

designed to move materials, parts, tools, or specialized devices through variable programmed motions for the performance of a variety of tasks, which also **acquire information from the environment** and move intelligently in response

- *ISO 8373* definition

an automatically controlled, reprogrammable, multipurpose manipulator programmable **in three or more axes**, which may be either **fixed in place or mobile** for use in industrial automation applications

- more general definition (“*visionary*”)

intelligent connection between **perception** and **action**



Robots !!



Comau H4
(1995)



Waseda WAM-8
(1984)



Spirit Rover
(2002)



A bit of history

- **Robota** (= “work” in slavic languages) are artificial human-like creatures built for being inexpensive workers in the theater play *Rossum’s Universal Robots (R.U.R.)* written by Karel Capek in 1920
- **Laws of Robotics** by Isaac Asimov in *I, Robot* (1950)
 1. **A robot may not injure a human being** or, through inaction, allow a human being to come to harm
 2. **A robot must obey orders given to it by human beings**, except where such orders would conflict with the First Law
 3. **A robot must protect its own existence** as long as such protection does not conflict with the First or Second Law



Evolution toward industrial robots

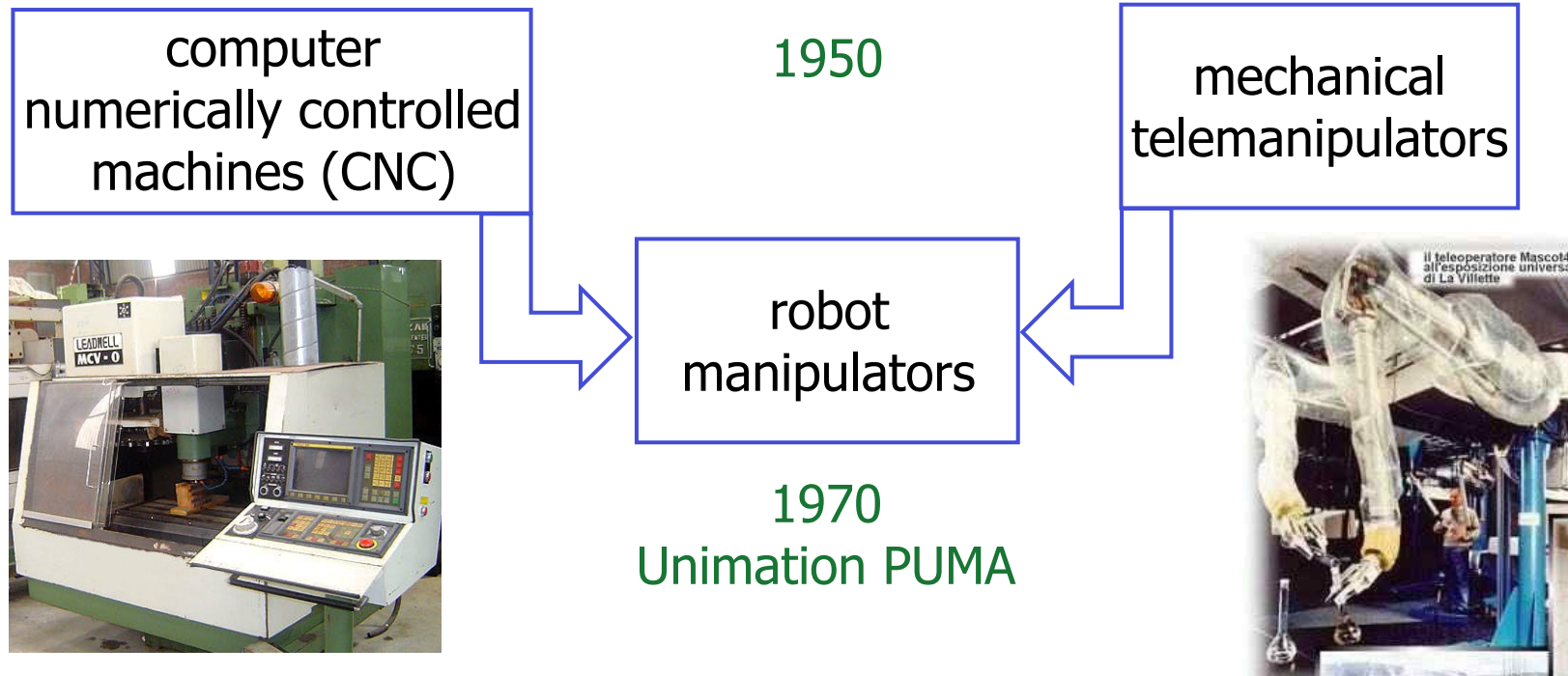

- with respect to the ancestors
 - **flexibility** of use
 - **adaptability** to a priori unknown conditions
 - **accuracy** in positioning
 - **repeatability** of operation



The first industrial robot

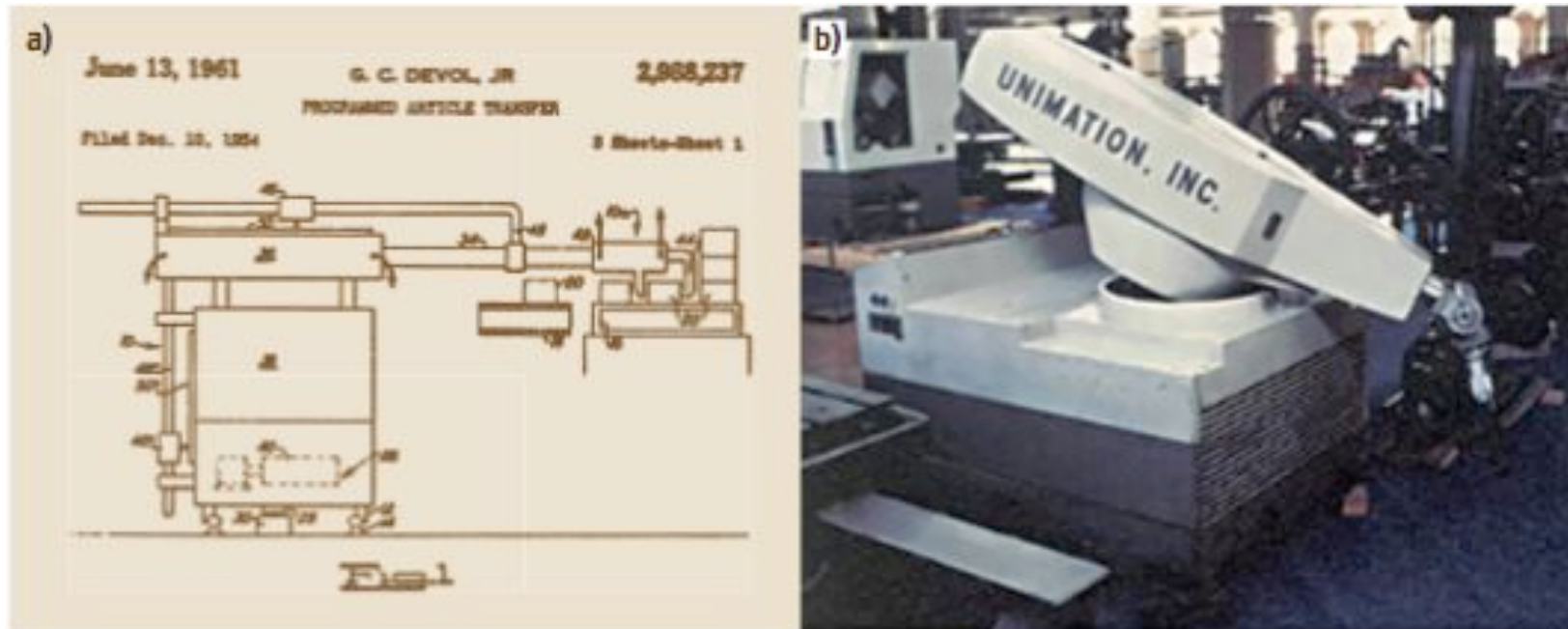

US Patent

General Motor plant, 1961

G. Devol and J. Engelberger (Unimation)



Robot manipulators

ASEA IRB-6
(1973)
first robot
all-electric-drives



Hirata AR-300
(1978)
first SCARA
robot

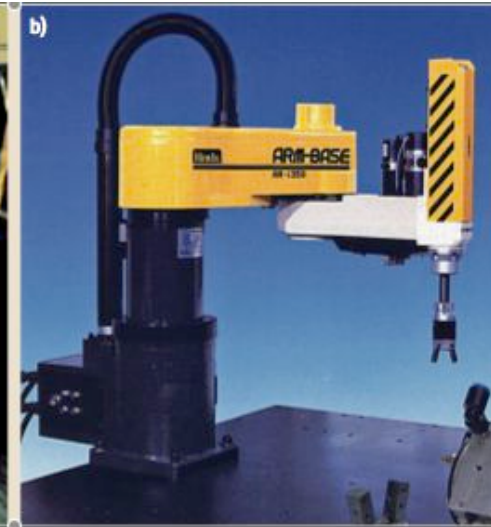

Cincinnati
Milacron T3
(1974)
first micro-
computer
controlled
robot



Unimation
PUMA 560
(1979)
6R with
human-like
dexterity



robots – a 50-year journey

robotics research up to 2000

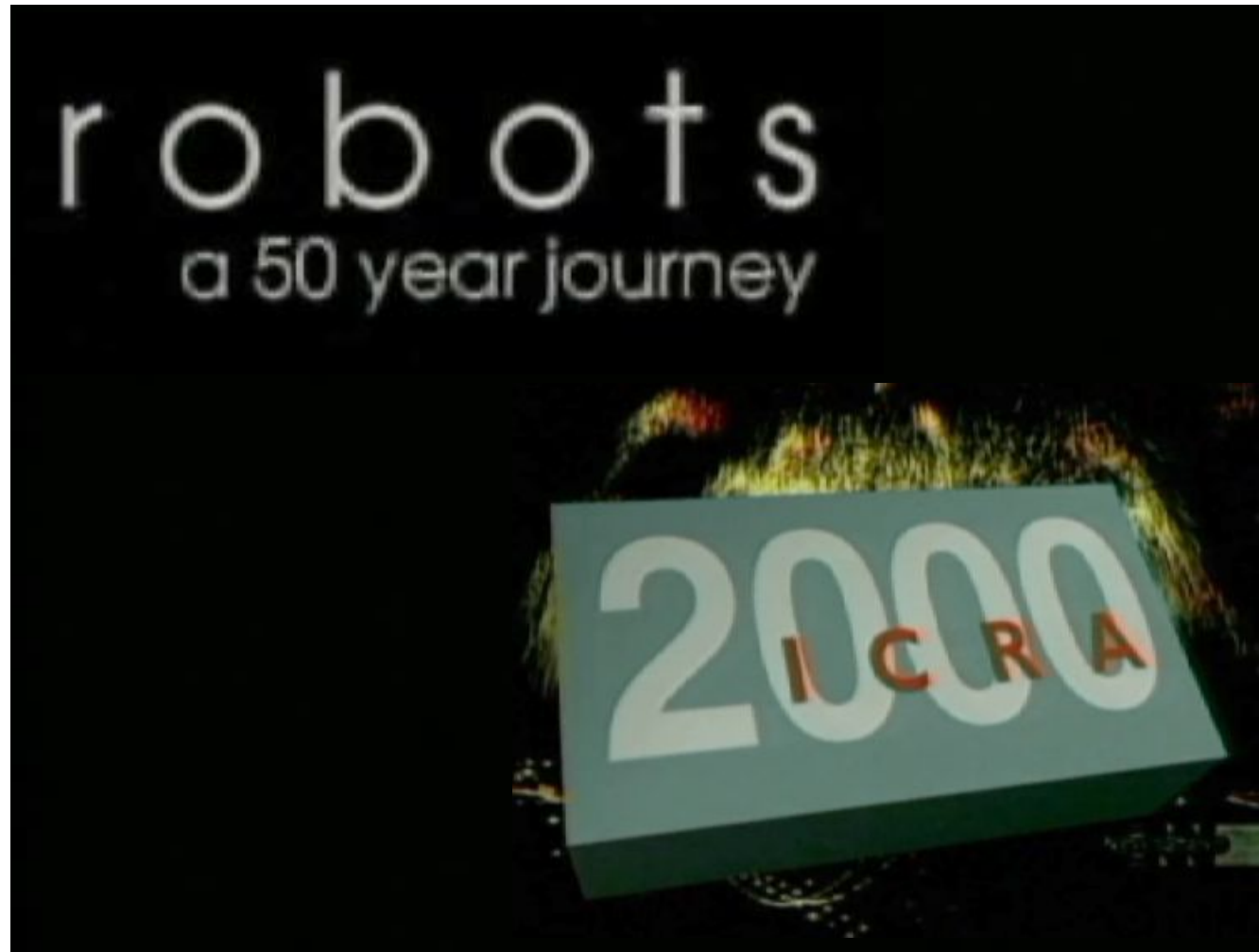

Video compiled for the IEEE ICRA 2000 conference, S. Francisco



World Robotics 2014

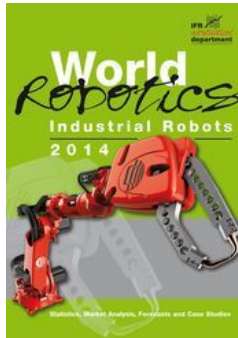

executive summary for 2014
yearly statistics by IFR
issued end of September



- robotics market value: **>\$10 billion** + software, peripherals, systems: **>\$30 billion**
- year 2013 was the highest in robot sales worldwide (180K)
- **China** is the biggest (for the first time) and fastest growing market
- decreased life-cycle and increased variety of products ask for increasingly more robots and automation
- research trends: energy efficiency, new materials, human-robot/machine collaboration
- service robotics (household, professional) is slowly catching up w.r.t. industrial robotics
 - 21K new robots for professional service sold in 2013



Diffusion

Industrial robots in operation worldwide

**Worldwide estimated operational stock of industrial robots
2002 - 2015***

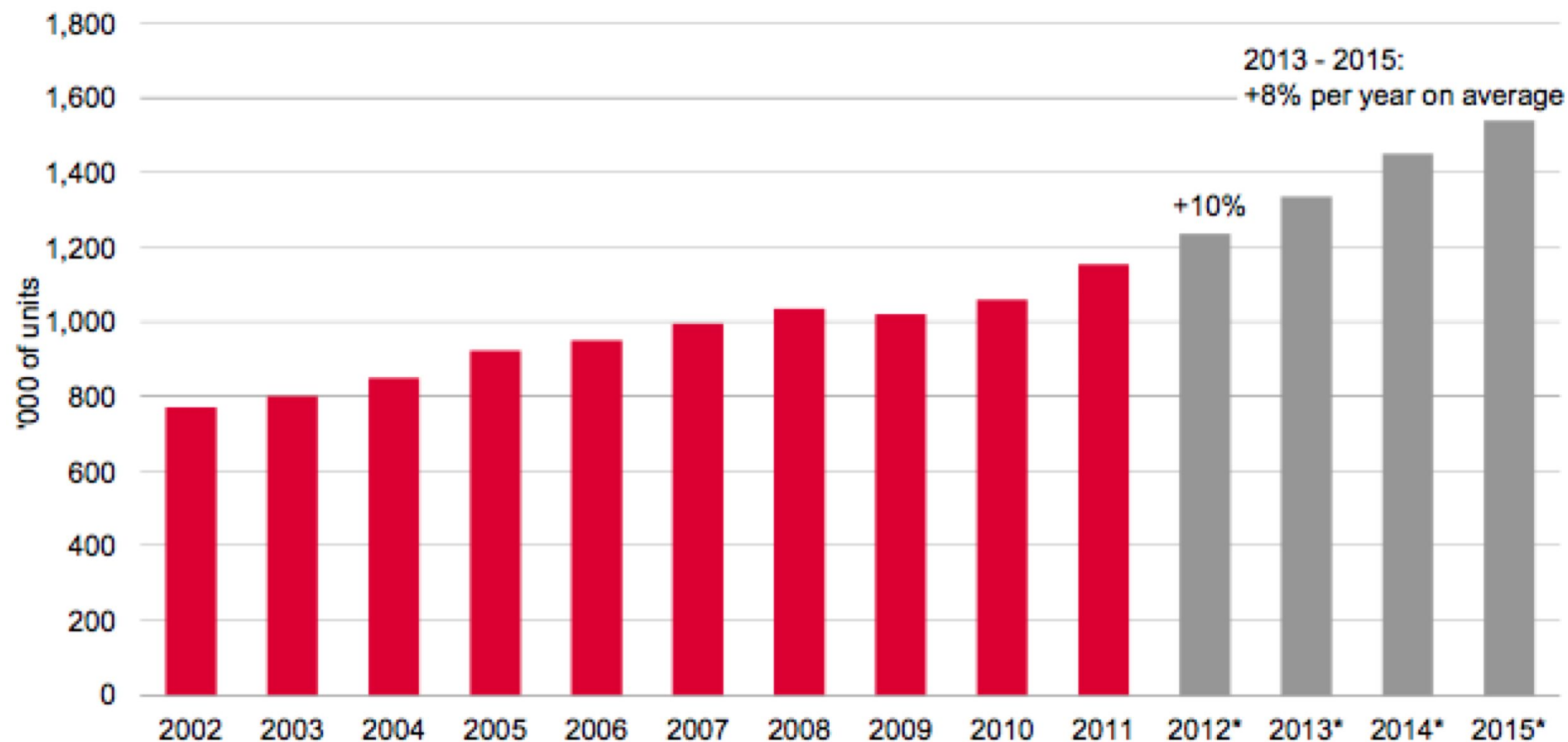

from World Robotics (2012)

* forecast

(as reference: industrial robots in stock in 1983 = 66K)
length of robot service life is estimated in 12-15 years



Diffusion

Industrial robots in operation by world regions

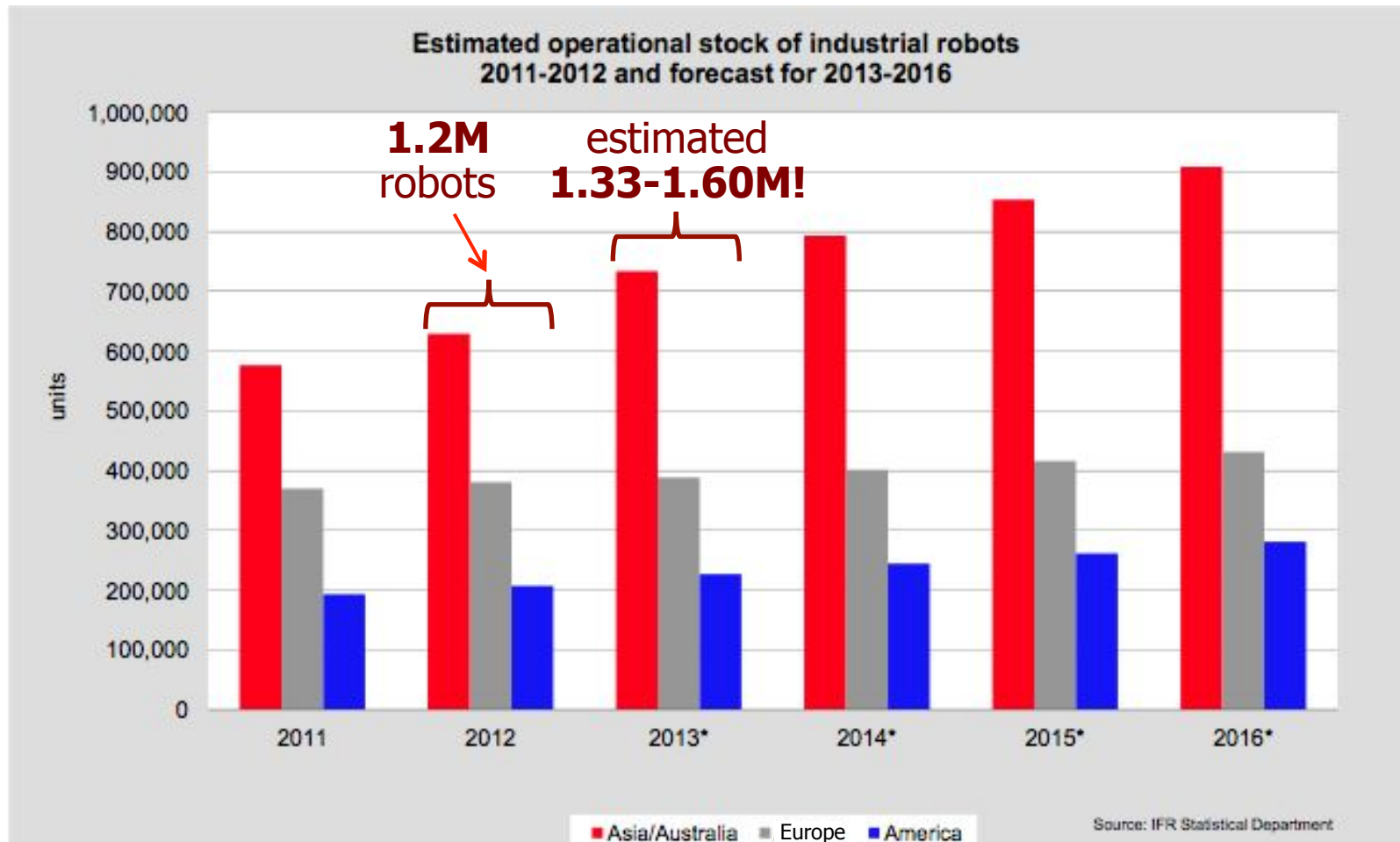

from World Robotics 2013



Annual supply

New industrial robots worldwide

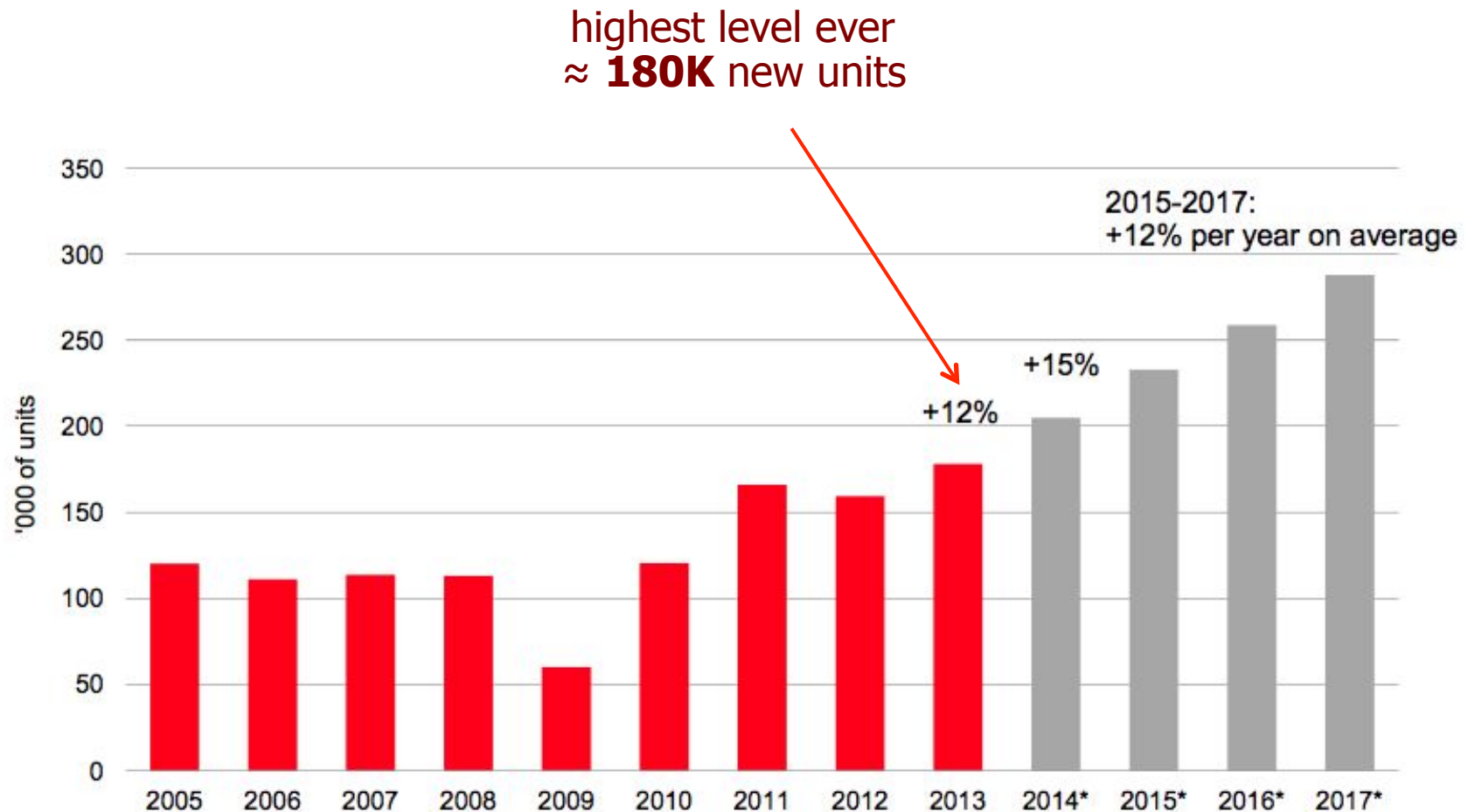

* forecast

World Robotics 2014

Annual supply

New industrial robots by world regions

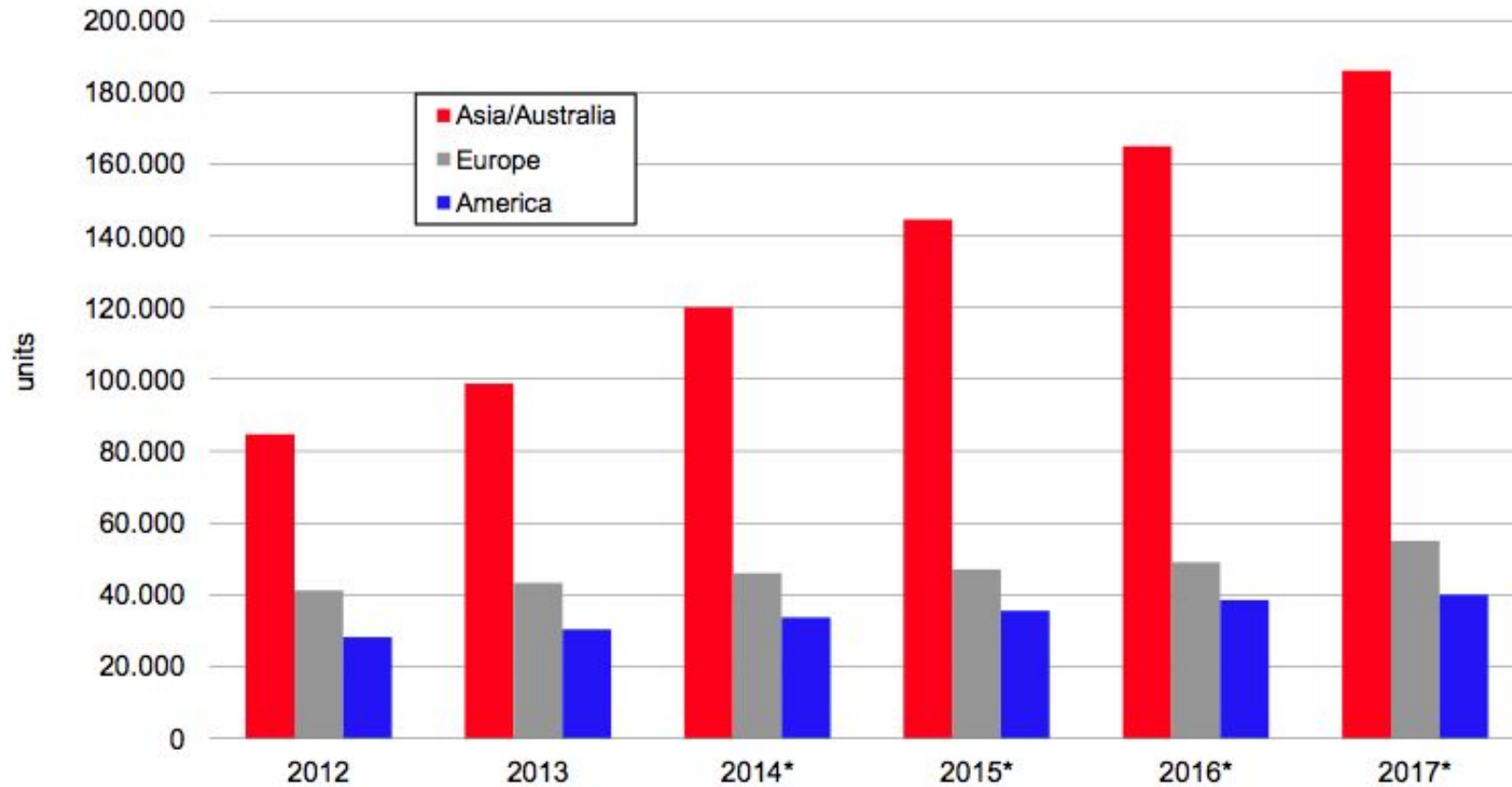

World Robotics 2014

*forecast: annual average growth of 10% in 2014–2017



Annual supply

Largest markets of new industrial robots

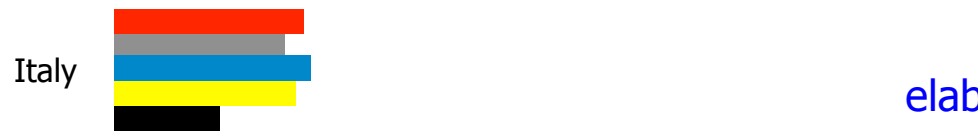
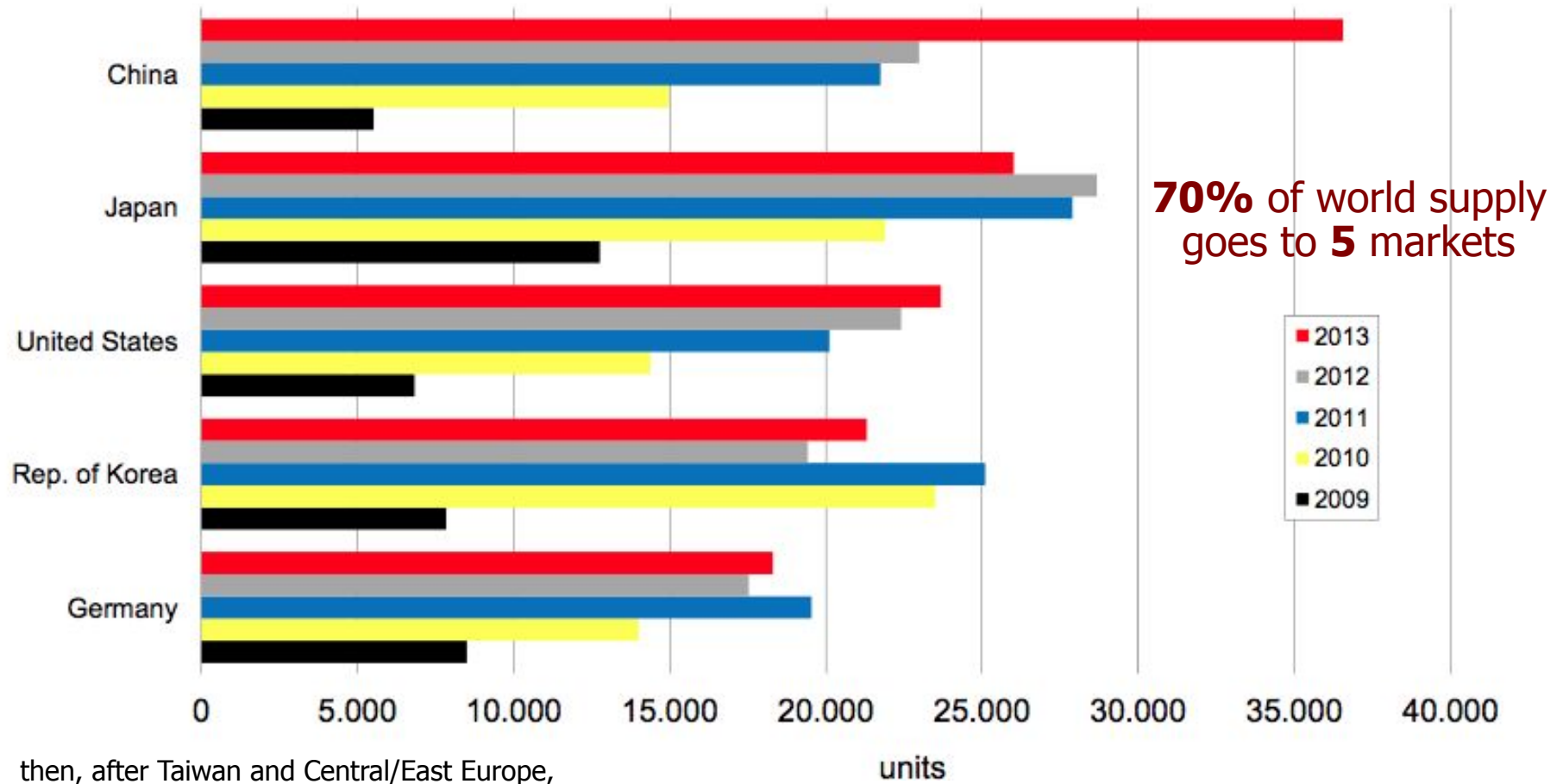

elaborated from World Robotics 2014

Annual supply

New robots by industrial sectors



Estimated worldwide annual supply of industrial robots at year-end by main industries 2010 - 2013

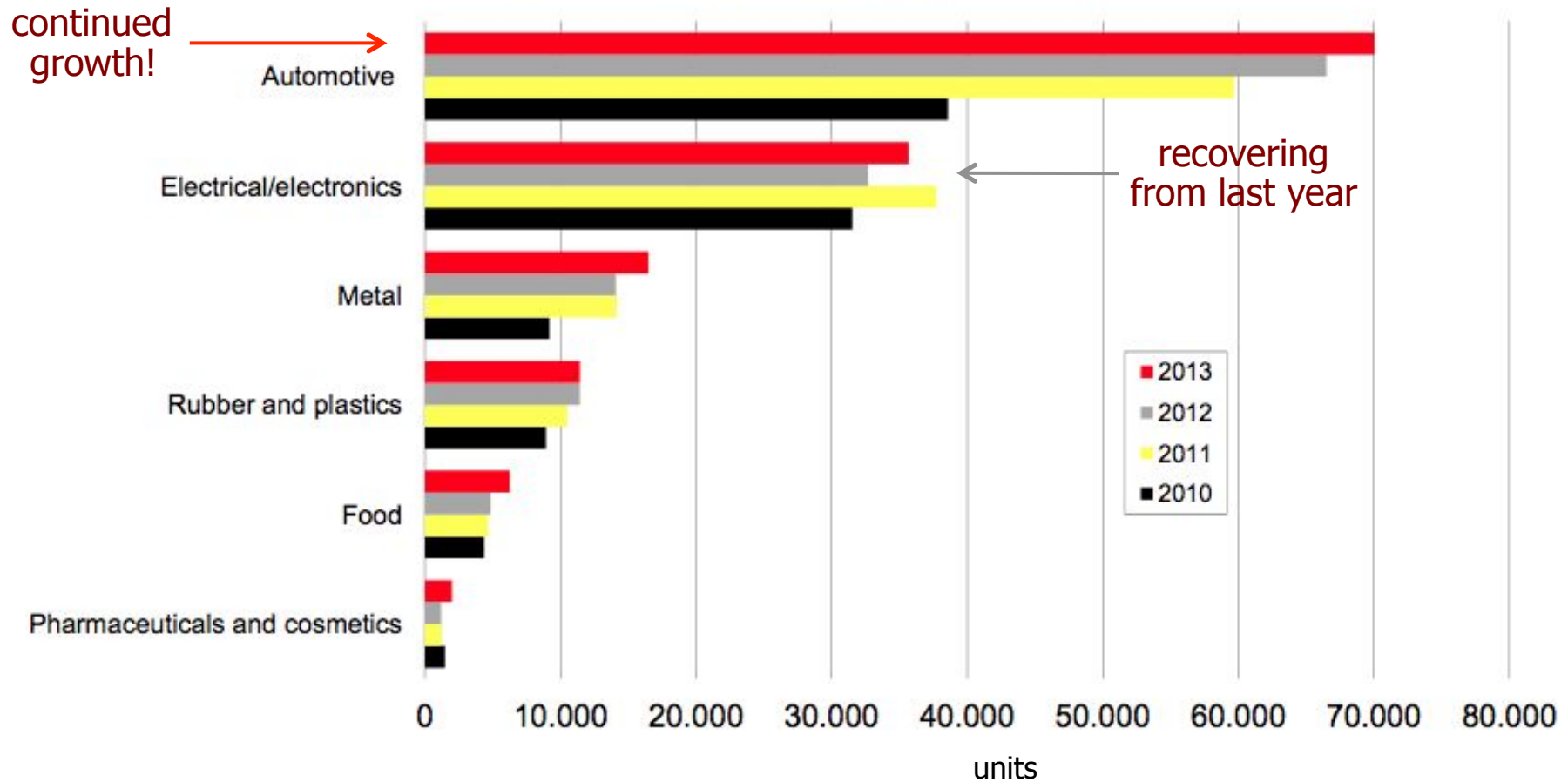

World Robotics 2014



Density of robots - 1

Number of multipurpose industrial robots (all types)
per 10,000 employees in the manufacturing industry (ISIC rev.4: C) 2011

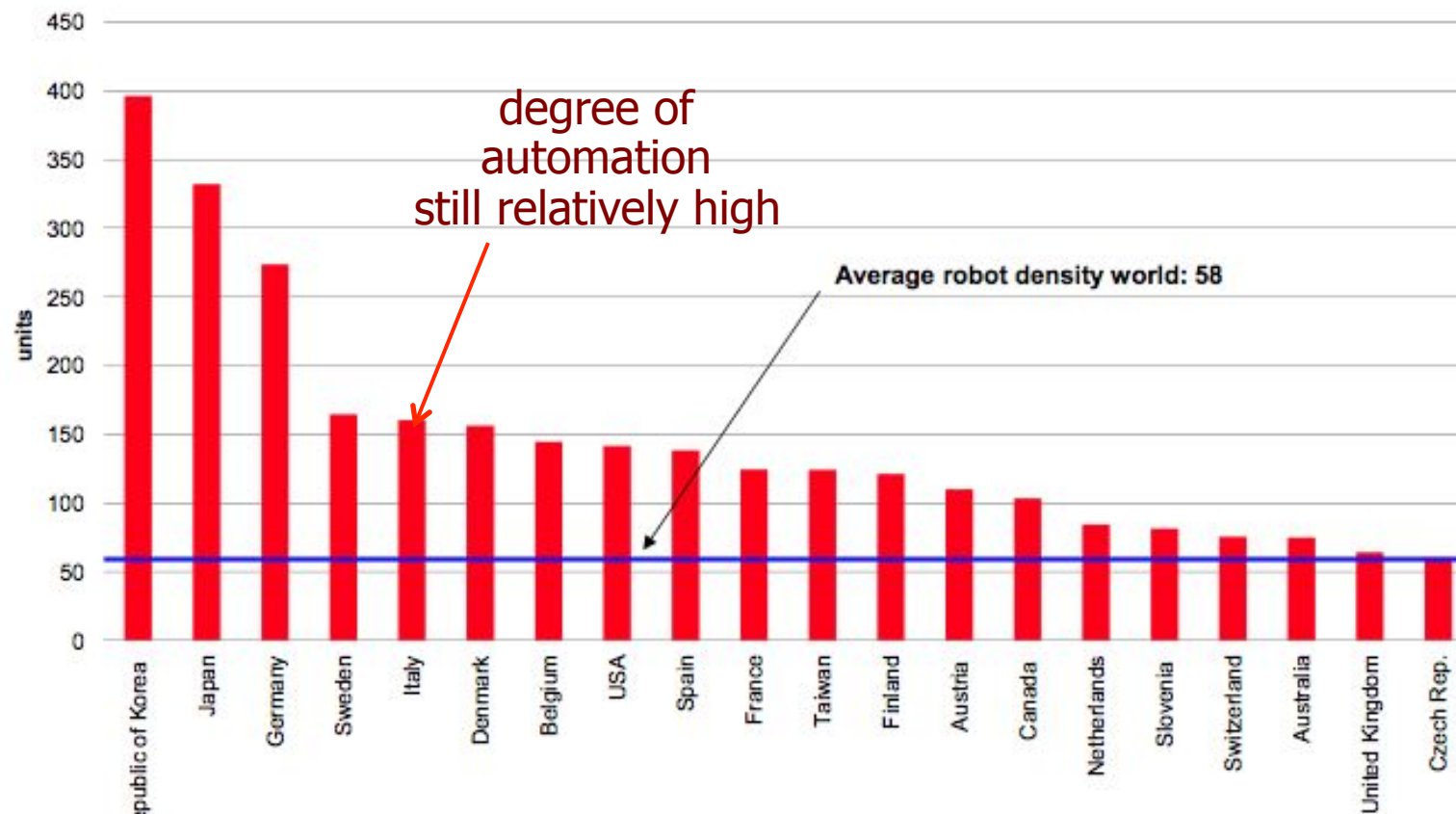

from World Robotics 2013

number of robots per 10000 employees
in the **manufacturing** industry in 2011



Density of robots - 2

Number of multipurpose industrial robots (all types)
per 10,000 employees in the automotive and in all other industries 2011

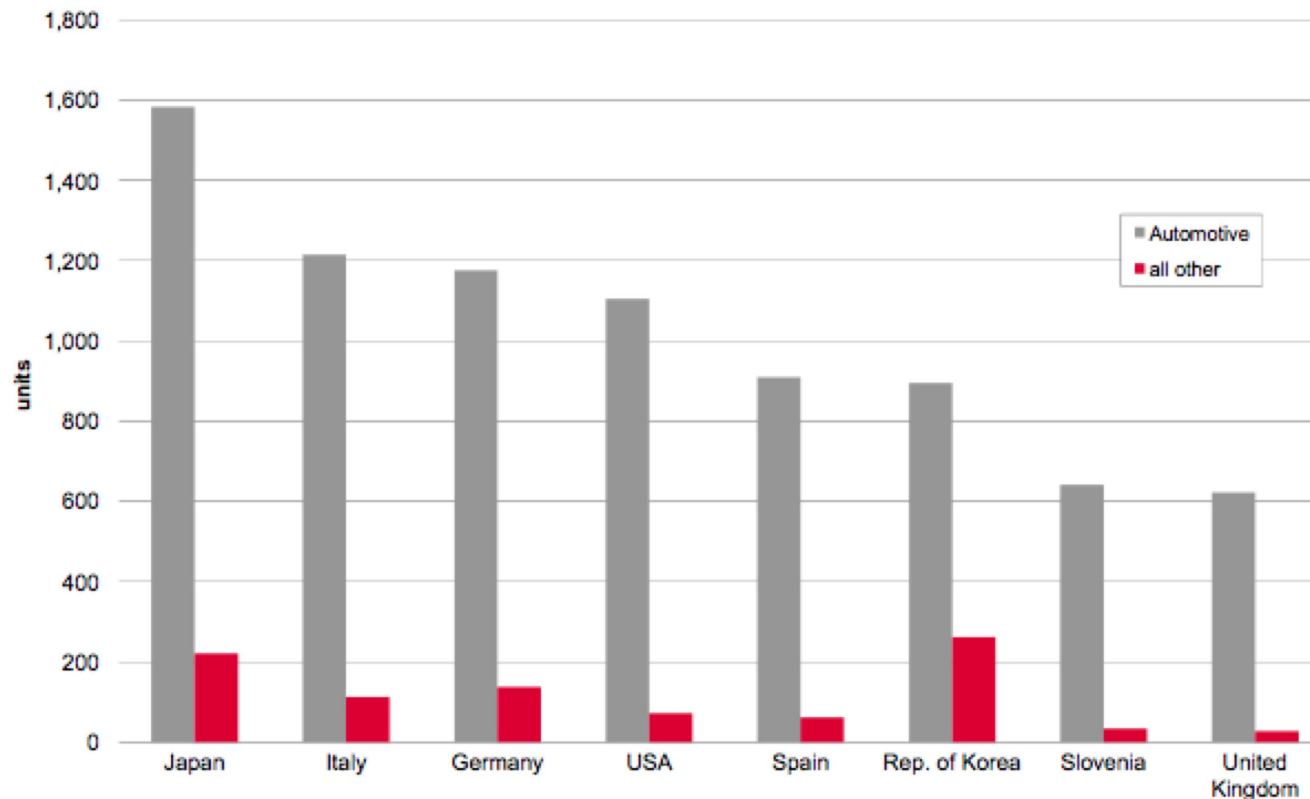

from World Robotics 2012

number of robots per 10000 employees
in the automotive and in **all other** industries in 2011



A long-range trend in robot prices

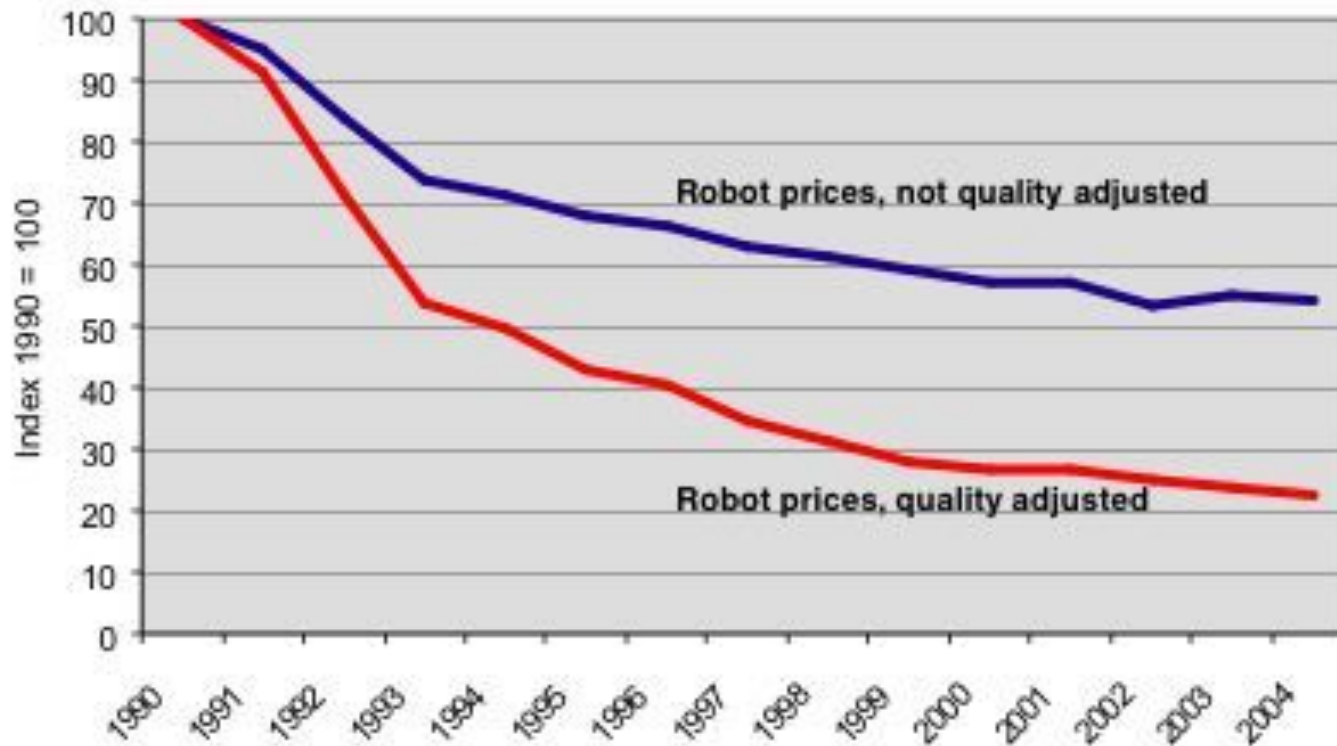

An articulated industrial robot with six degrees of freedom of medium/large size costs **about 100 KEuro**

Industrial robot and its auxiliary equipments



1. Comau SMART H robot
2. C3G Plus controller
3. Welding control box
4. Application software
5. Air/water supply
6. SWIM Board
7. Integrated cables
8. Welding gun
9. Auxiliary devices in the robotic cell (servo-controlled axes)

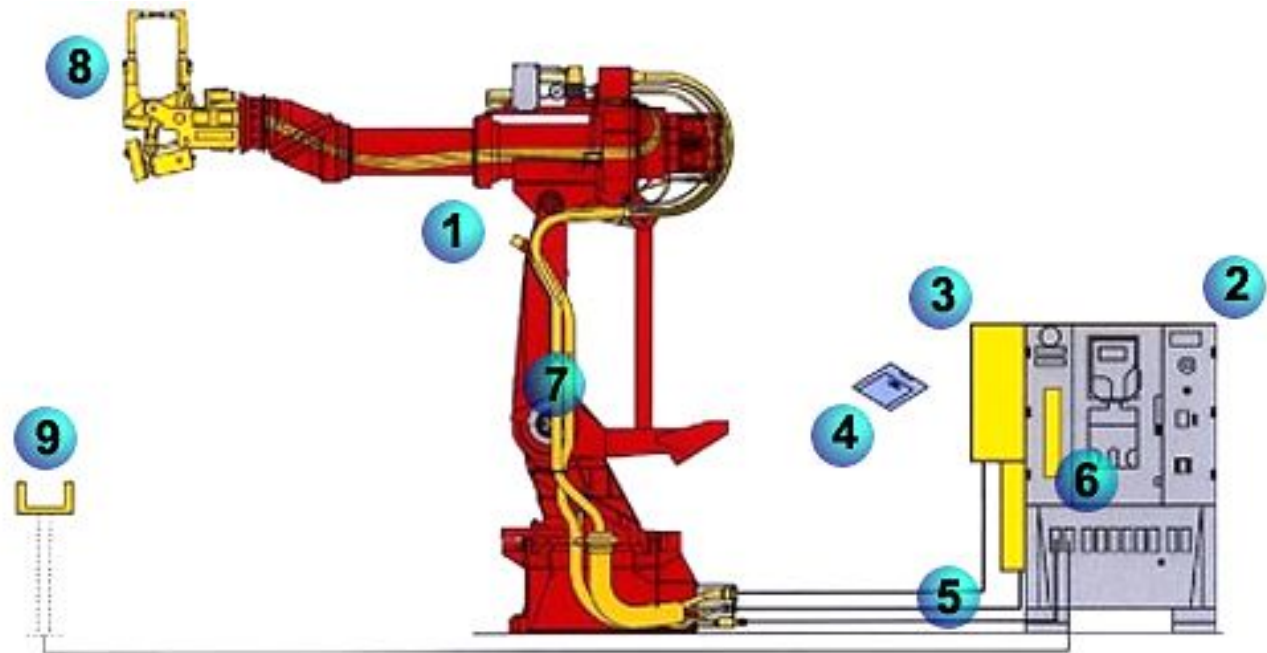

SWIM = Spot Welding Integrated Module



ABB IRB 7600



commercial [video](#) by ABB



Industrial applications

- manipulation (pick-and-place)
- assembly
- spray painting and coating
- arc welding
- spot welding with pneumatic or servo-controlled gun
- laser cutting and welding
- gluing and sealing
- mechanical finishing operations (deburring, grinding)





Plasma cutting

video

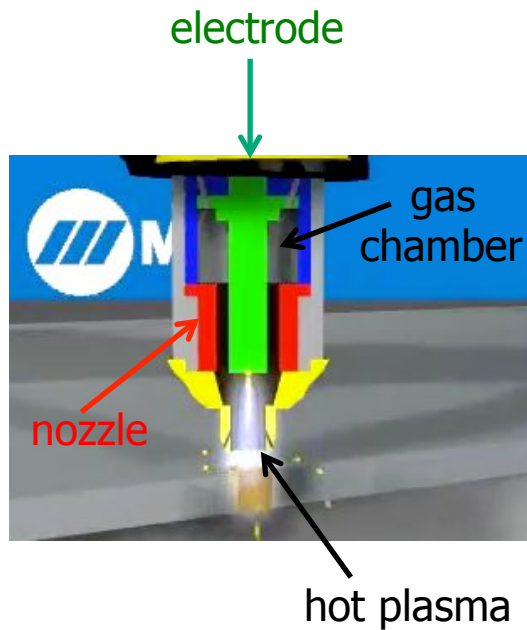

small KUKA robot used for plasma cutting of a stainless steel toilet
(courtesy of Engenious Solutions Pty)



Robotized workcells

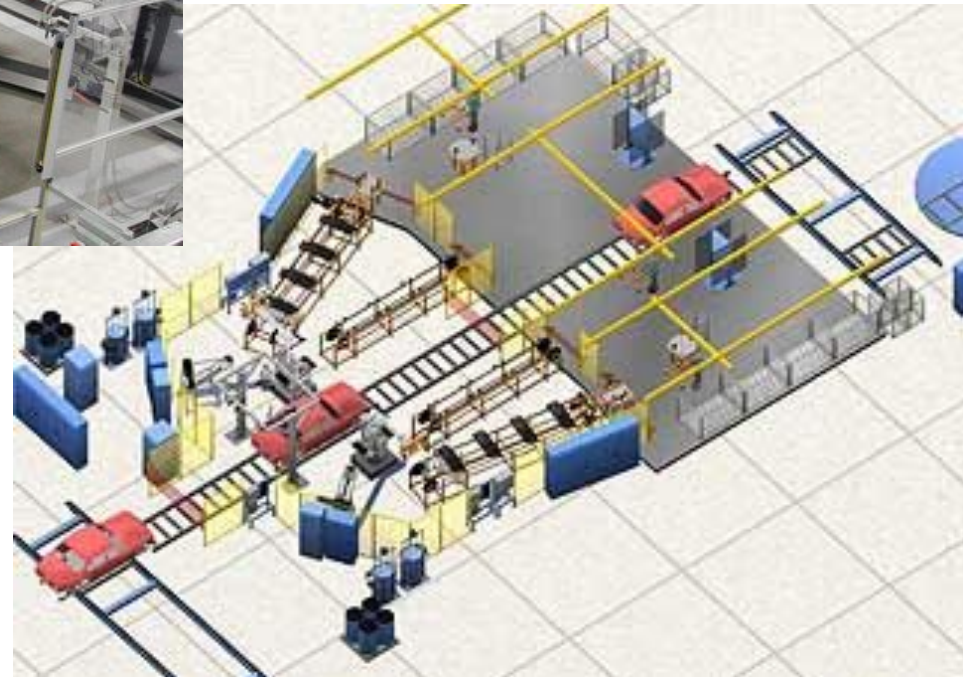

3D simulation of robotic tasks

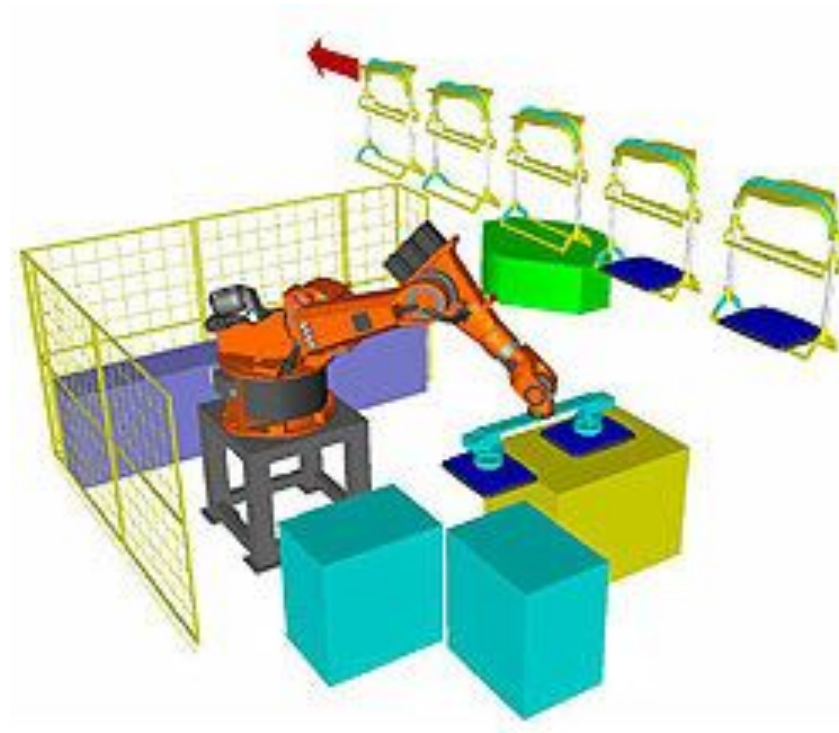

- analysis of operative cycle times
- off-line programming and optimization
- layout design and collision checking
- 3D graphic simulation



Welding - 1

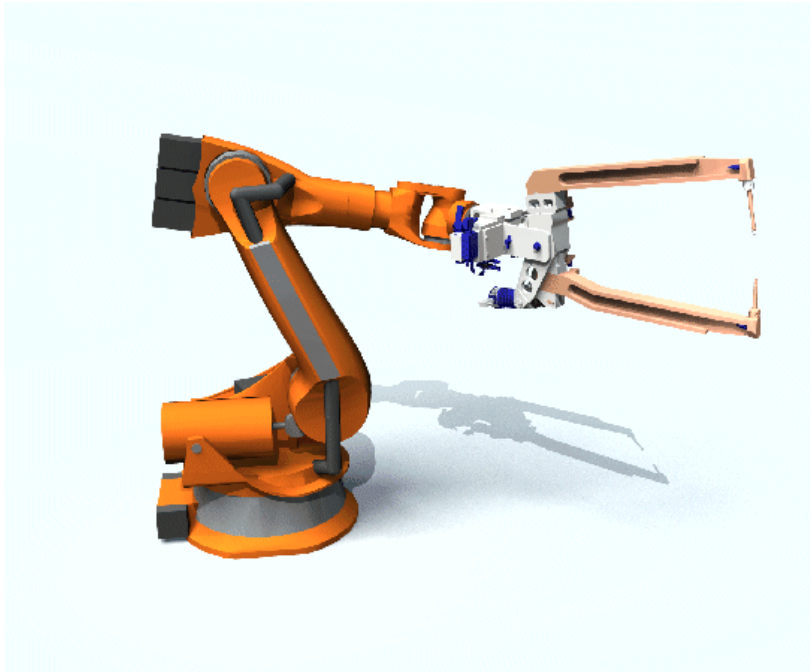

- spot with servo-controlled gun

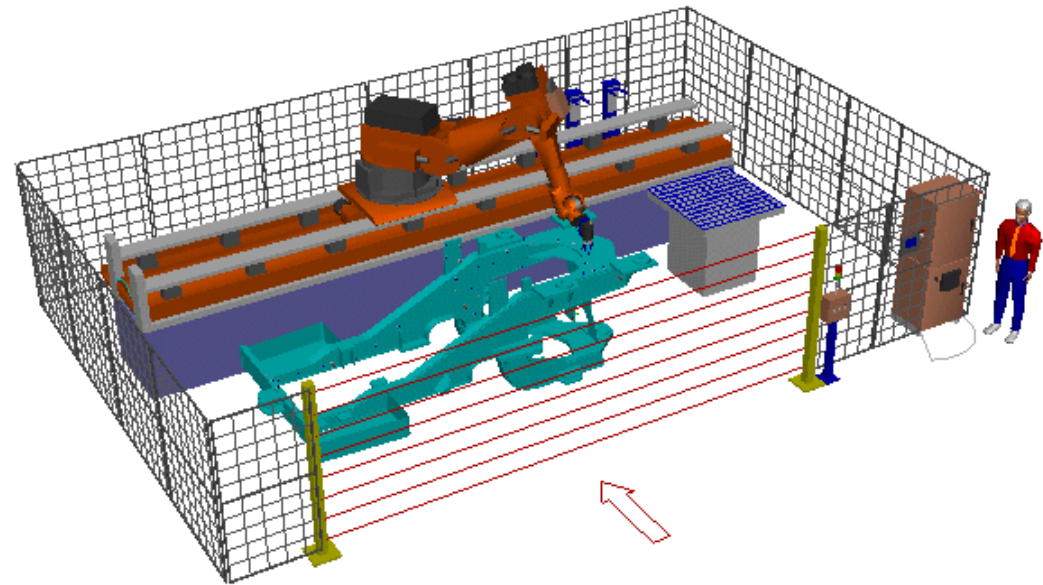

- stud welding

Welding - 2



- spot (discrete) or arc (continuous)



Two cooperating robots in welding



ABB [video](#) at Laxa, Sweden



Palletizing

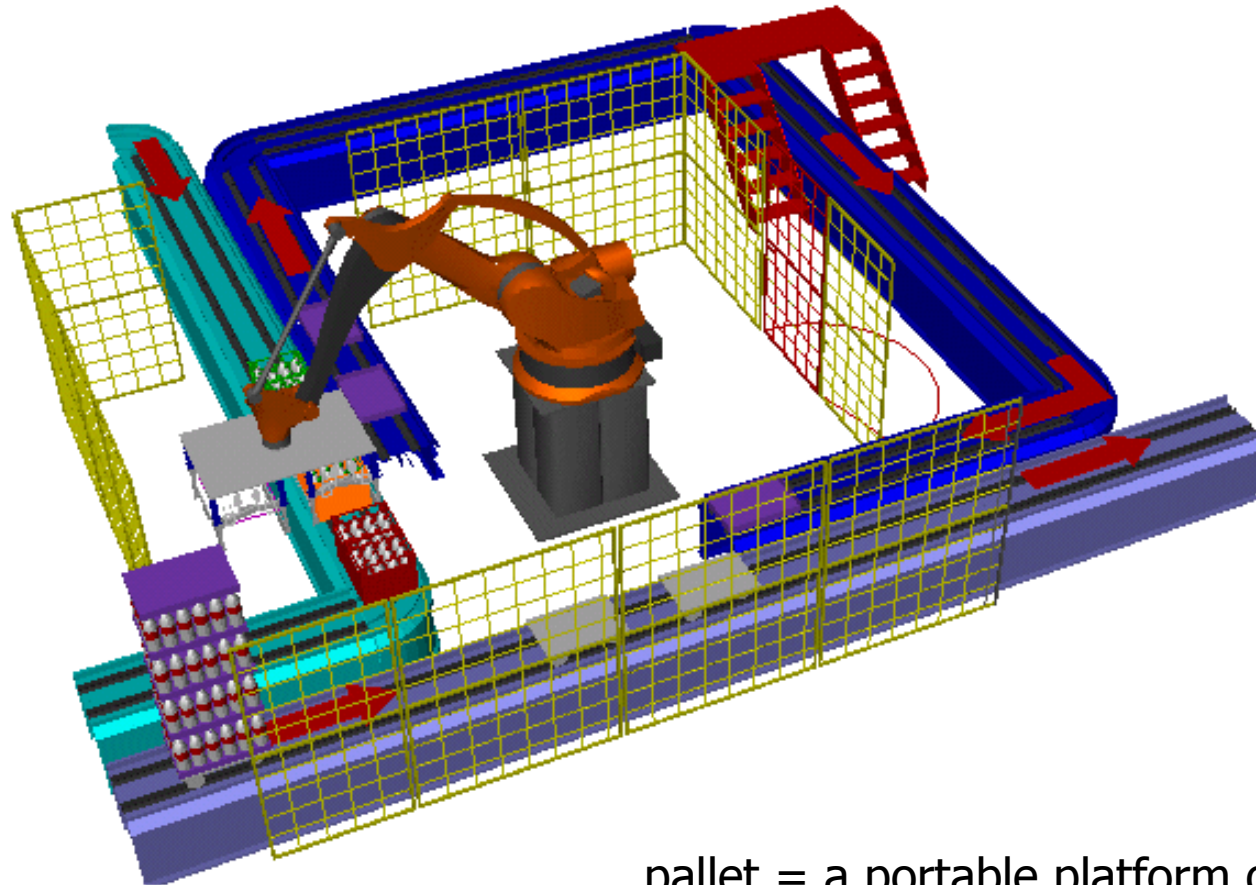

pallet = a portable platform on which goods can be moved, stacked, and stored



Palletizing of cheese forms

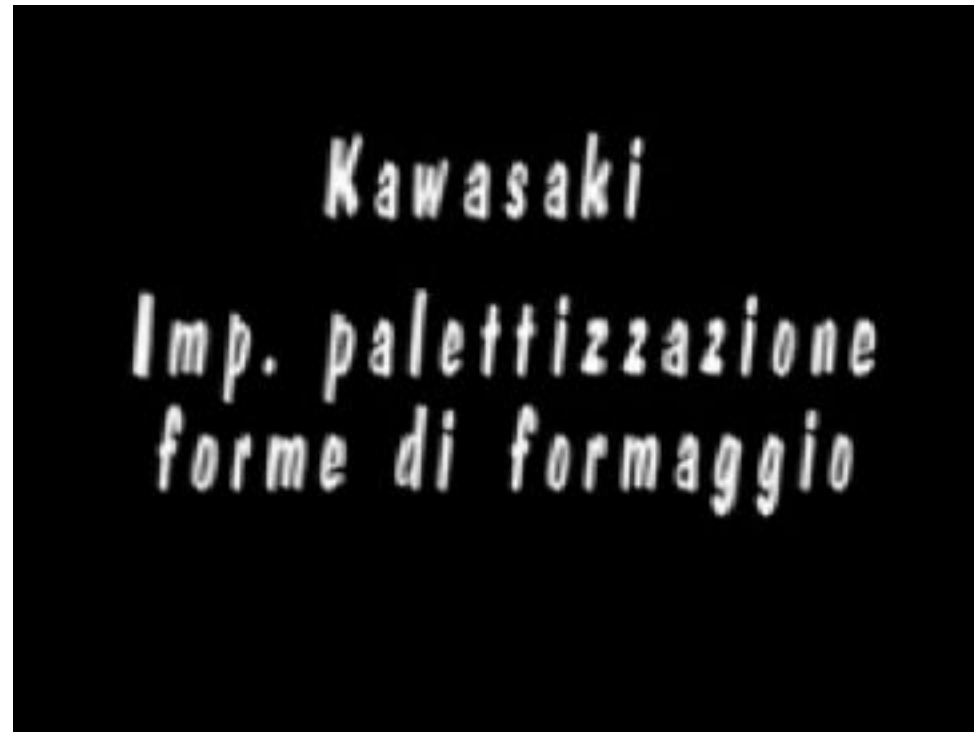

video

using Kawasaki robots (courtesy of Efedue Engineering)



Folding

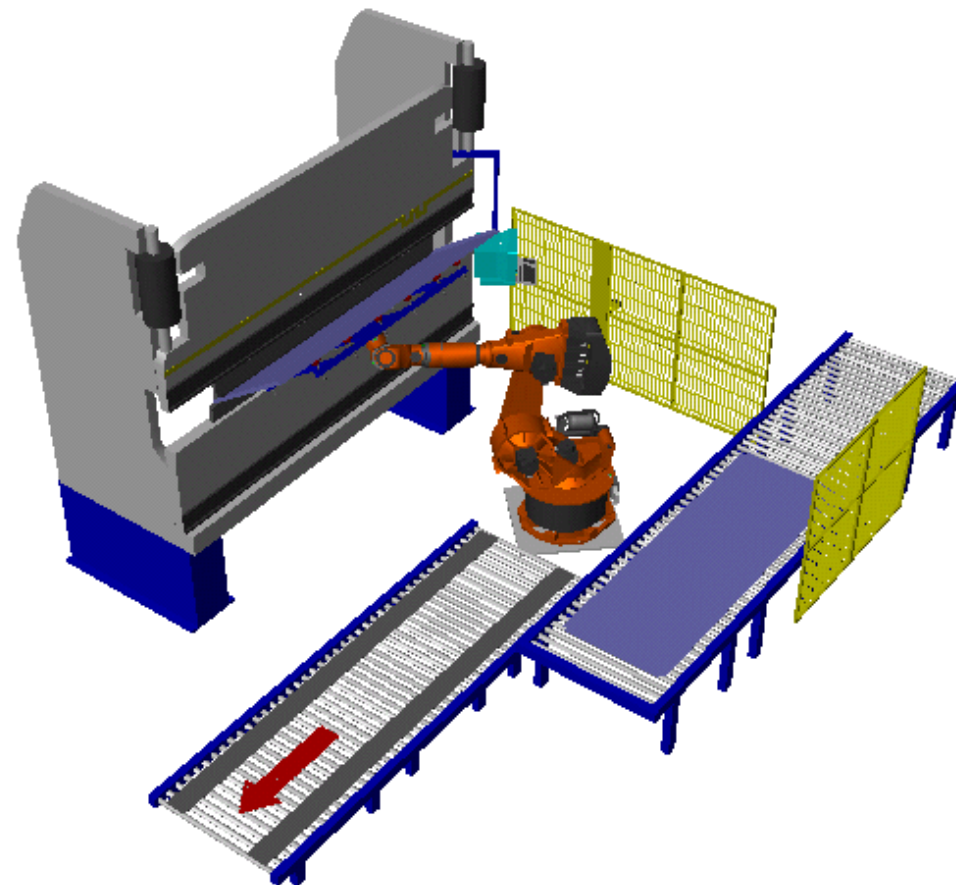

with loading of sheets under the press



Deburring

- car windshields may have large manufacturing tolerances and a sharp contour profile

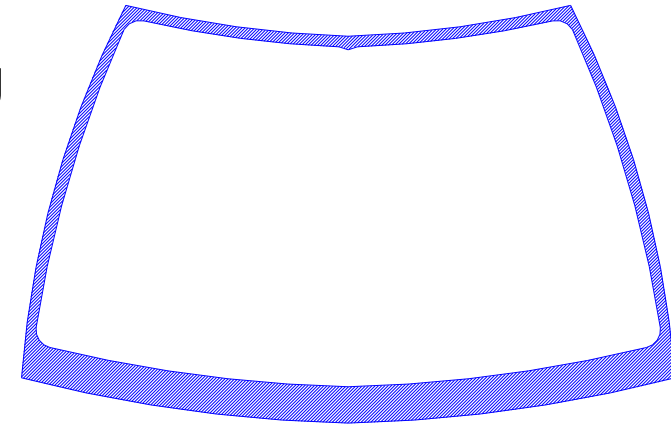
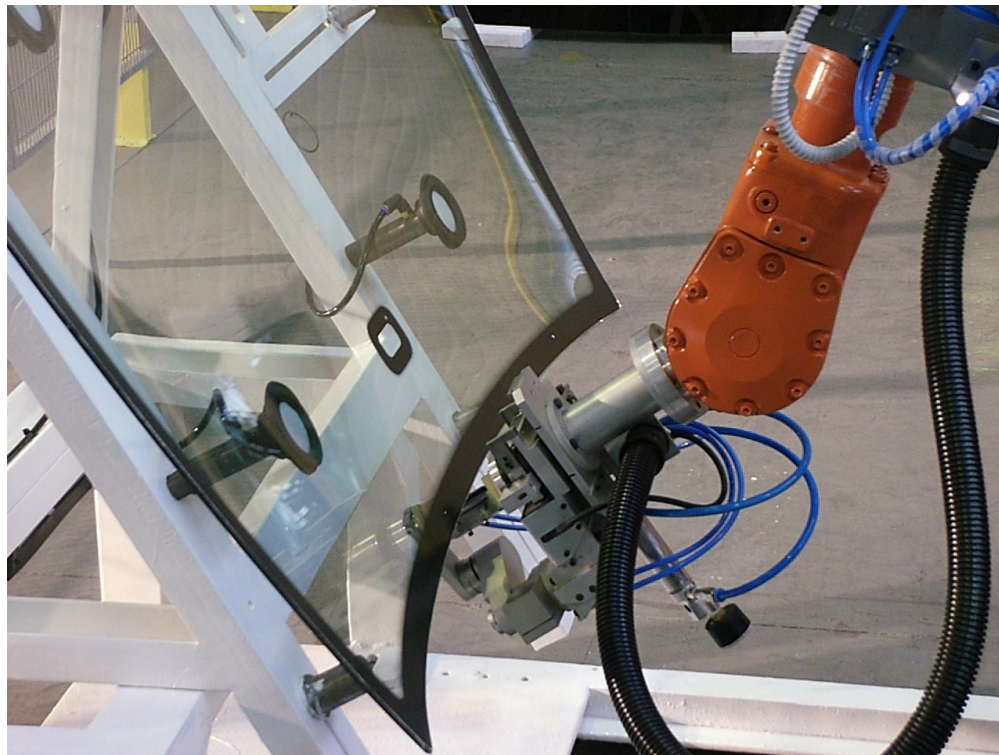

- the robot follows a given predefined Cartesian path
- the contact force between cutting blade and glass must be feedback controlled
- deburring robot head mounts a force load cell and is pneumatically actuated



Deburring center

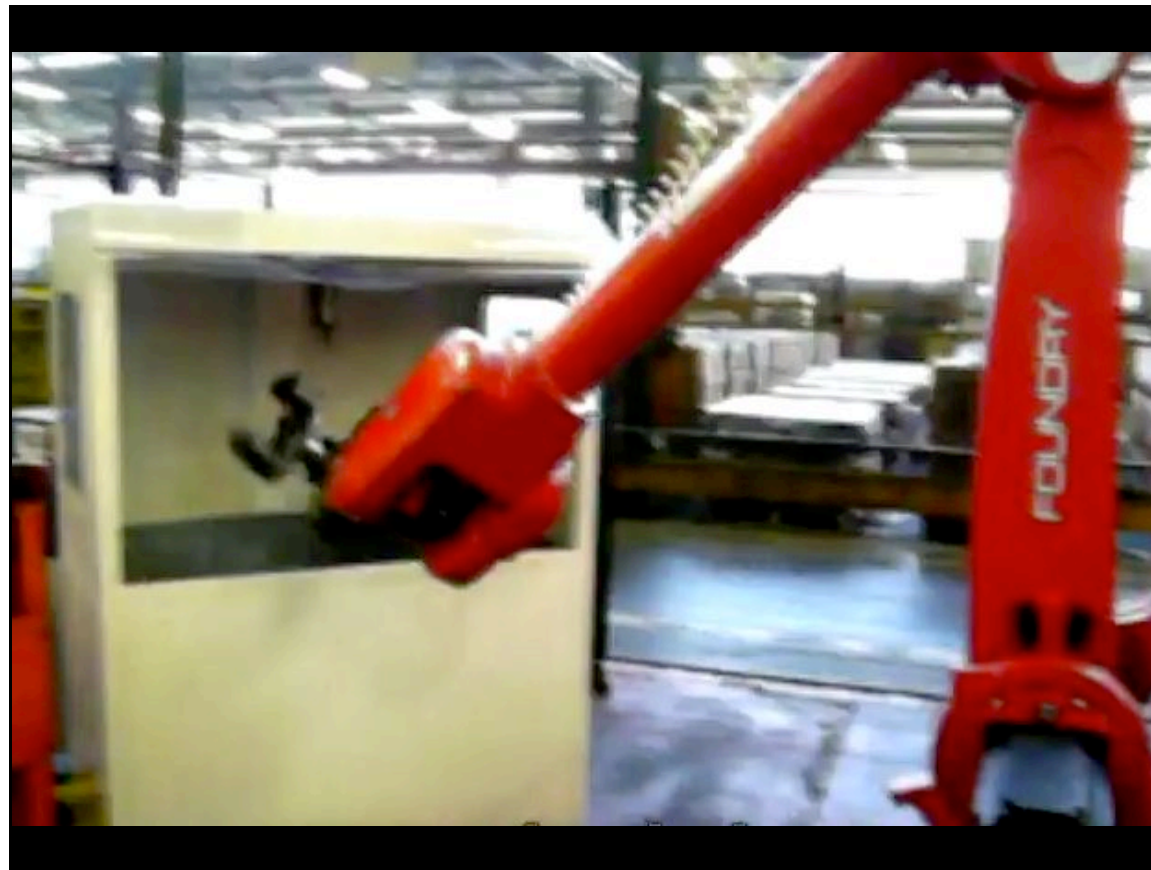

video

deburring center for steel parts
using Comau SMART NJ 110-3.0/foundry robot (courtesy of Adami srl)



Off-line robot workstation

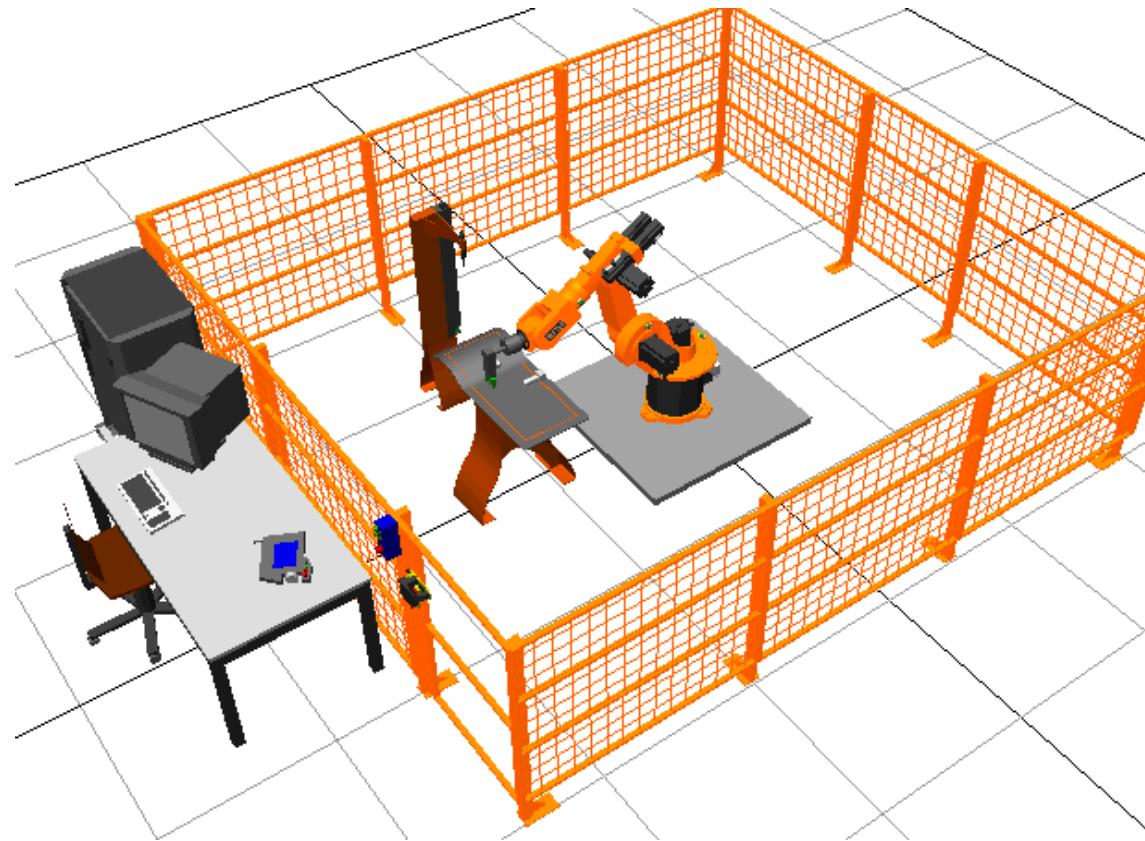

articulated robot in metal surface finishing operation



Safety in robotic cells



commercial [video](#) from ABB
SafeMove cell monitoring system (no fences!)



Robot manipulator kinematics



Kuka 150_2
(series 2000)
open kinematic chain
(rigid bodies
connected by joints)



Comau
Smart H4
closed kinematic chain



Fanuc
F-200iB
parallel kinematics



Other types of robots - 1



Mitsubishi RP
(repeatability 5 micron,
payload 5 kg)



Mitsubishi RH
(workspace 850 mm,
velocity 5 m/s)



Bosch Turbo

SCARA (Selective Compliant Arm for Robotic Assembly)

- 4 degrees of freedom (= joints): 3 revolute + 1 prismatic (vertical) axes
- compliant in horizontal plane for micro-assembly and pick-and-place



Adept Cobra i600



video

fastest SCARA robot for pick-and-place tasks!



Other types of robots - 2



Comau Mast
gantry robot
(payload up to 560 kg)



ABB Flexpicker
(150 pick-and-place
operations/minute)

Chocolate packaging with lightweight parallel robots

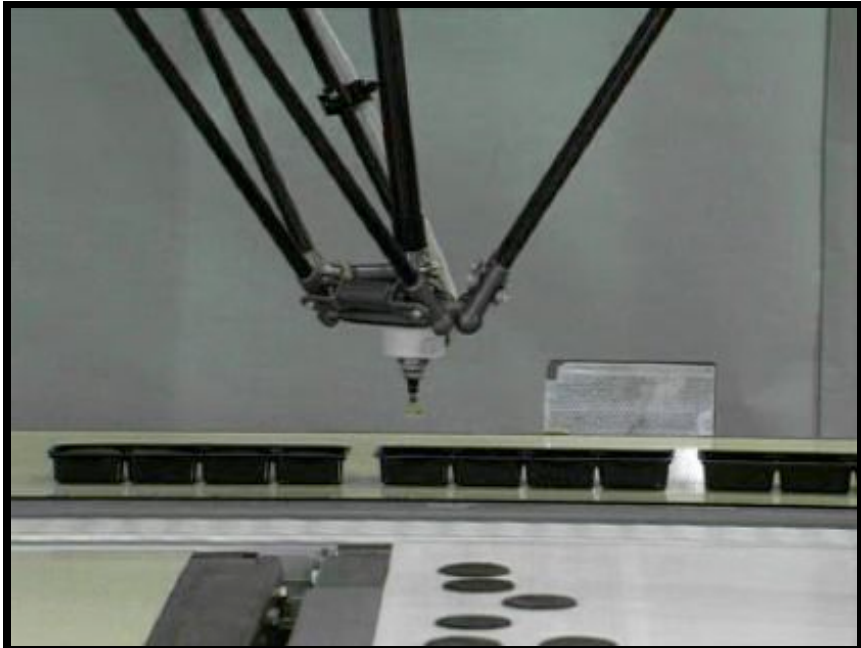

test [video](#) with
ABB Flexpicker



[video](#) with
Adept Quatro s650



Distribution by robot type

of kinematic configuration

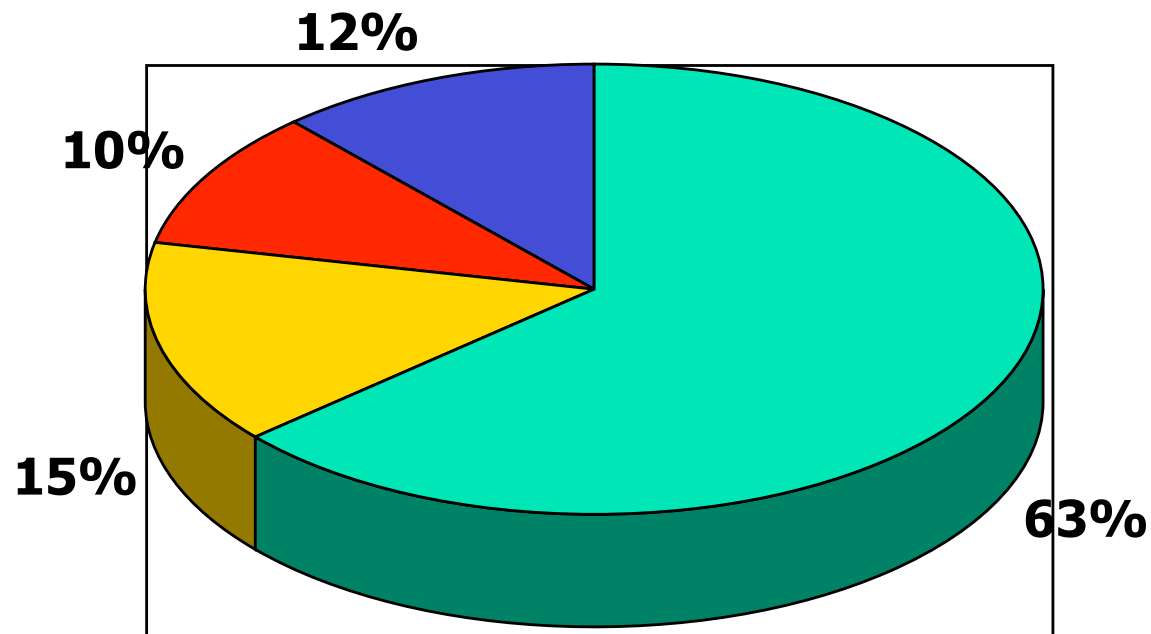

■ articulated ■ cartesian/gantry ■ cylindric ■ SCARA

for 59600 articulated robots installed in 2004
(90% of all robots installed in America, 74% in Europe, only 49% in Asia)



Robot data sheet



Fanuc
R-2000i/165F

Specifiche tecniche

Voce	R-2000i/165F	
Tipo	Articolato	
Assi controllati	6 assi (J1, J2, J3, J4, J5, J6)	
Installazione	A pavimento	
Area di lavoro (Velocità massima)	Rotazione asse J1	360° (105°/s)
	Rotazione asse J2	135° (105°/s)
	Rotazione asse J3	361,8° (105°/s)
	Rotazione asse J4	720° (130°/s)
	Rotazione asse J5	250° (130°/s)
	Rotazione asse J6	720° (210°/s)
Carico massimo al polso	165 kg	
Momento di carico max. al polso (Nota 1)	Asse J4	94 kgfm 921 Nm
	Asse J5	94 kgfm 921 Nm
	Asse J6	47 kgfm 461 Nm
Momento di inerzia max. al polso	Asse J4	800 kgfcm ² 78,4 kgm ²
	Asse J5	800 kgfcm ² 78,4 kgm ²
	Asse J6	410 kgfcm ² 40,12 kgm ²
Tipo di azionamento	Motori elettrici AC	
Ripetibilità	± 0,3 mm	
Peso	1.210 kg	
Ambiente Installazione	Temperatura ambiente:	0-45° C
	Umidità ambiente	
	Normale:	≤ 75%
	Breve (in un mese)	≤ 95%
	Vibrazioni	0,5 G max.



Workspace

Area di lavoro
Operating Space

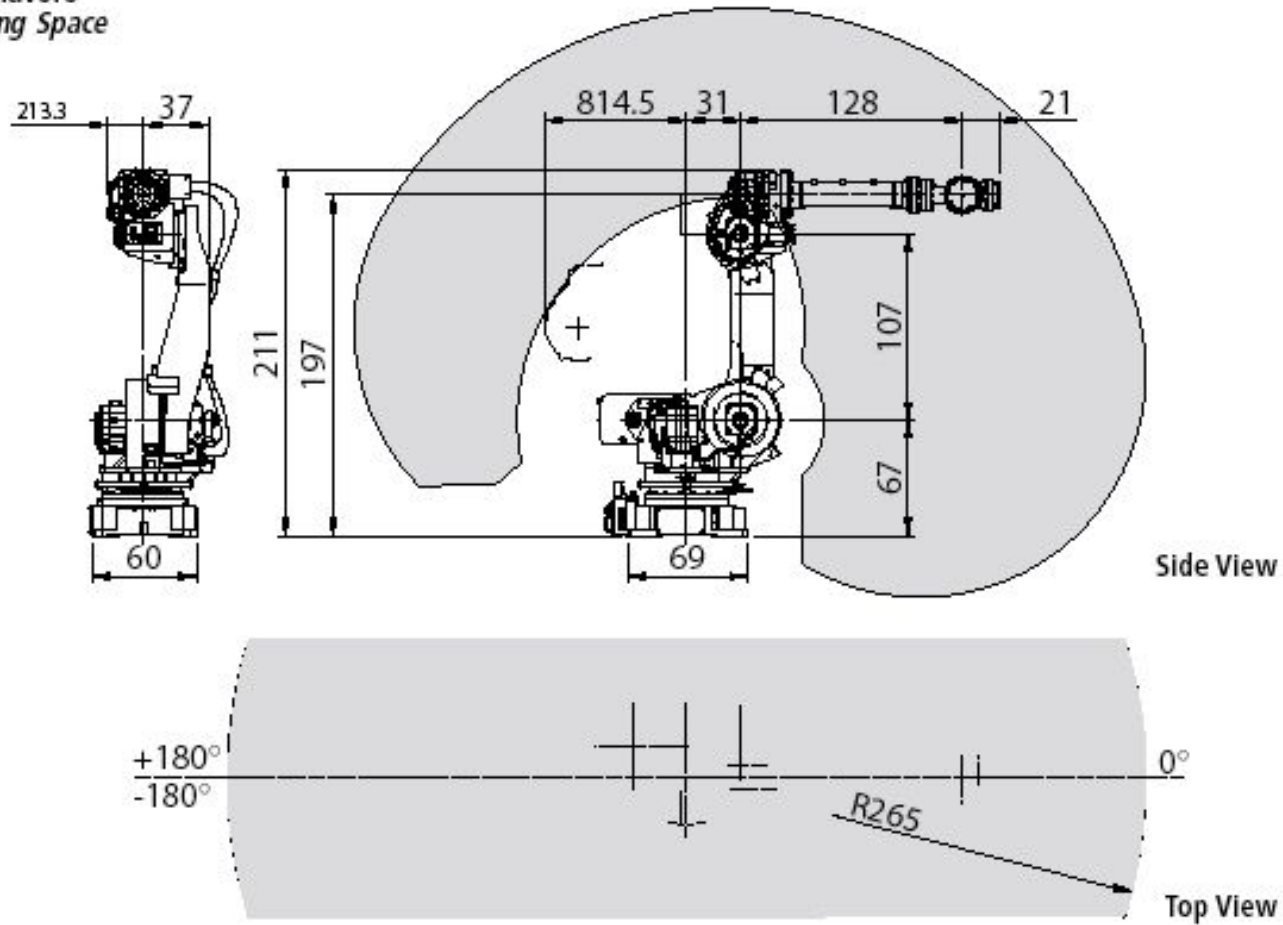

Visualization of workspace and mobility



video

kinematic simulation of a 6-dof Comau robot (all revolute joints)

Visualization of workspace and mobility



video

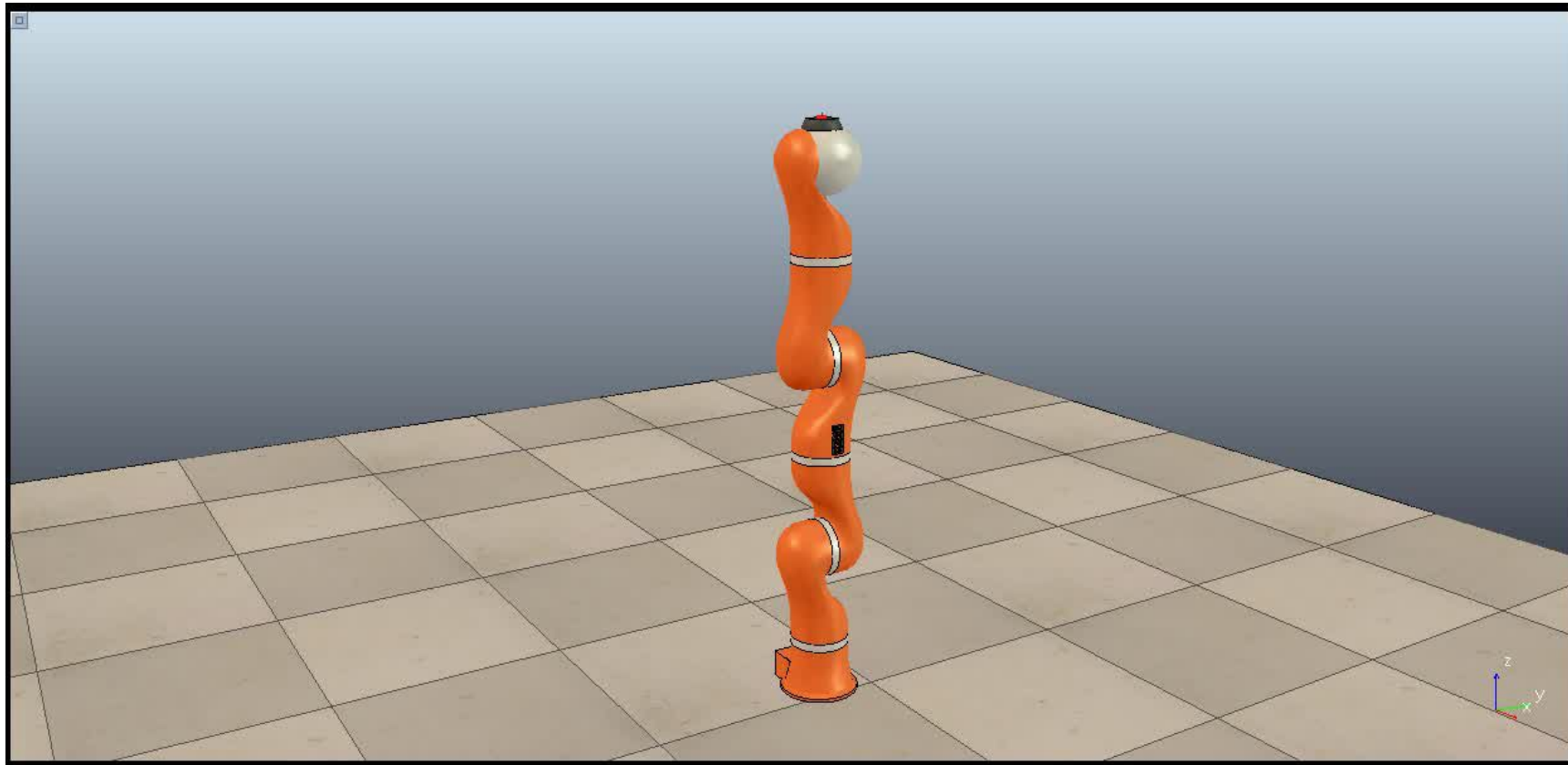

V-REP simulation of the 7-dof KUKA LWR4+ robot (all revolute joints)

Robot end-effector sensors and tools

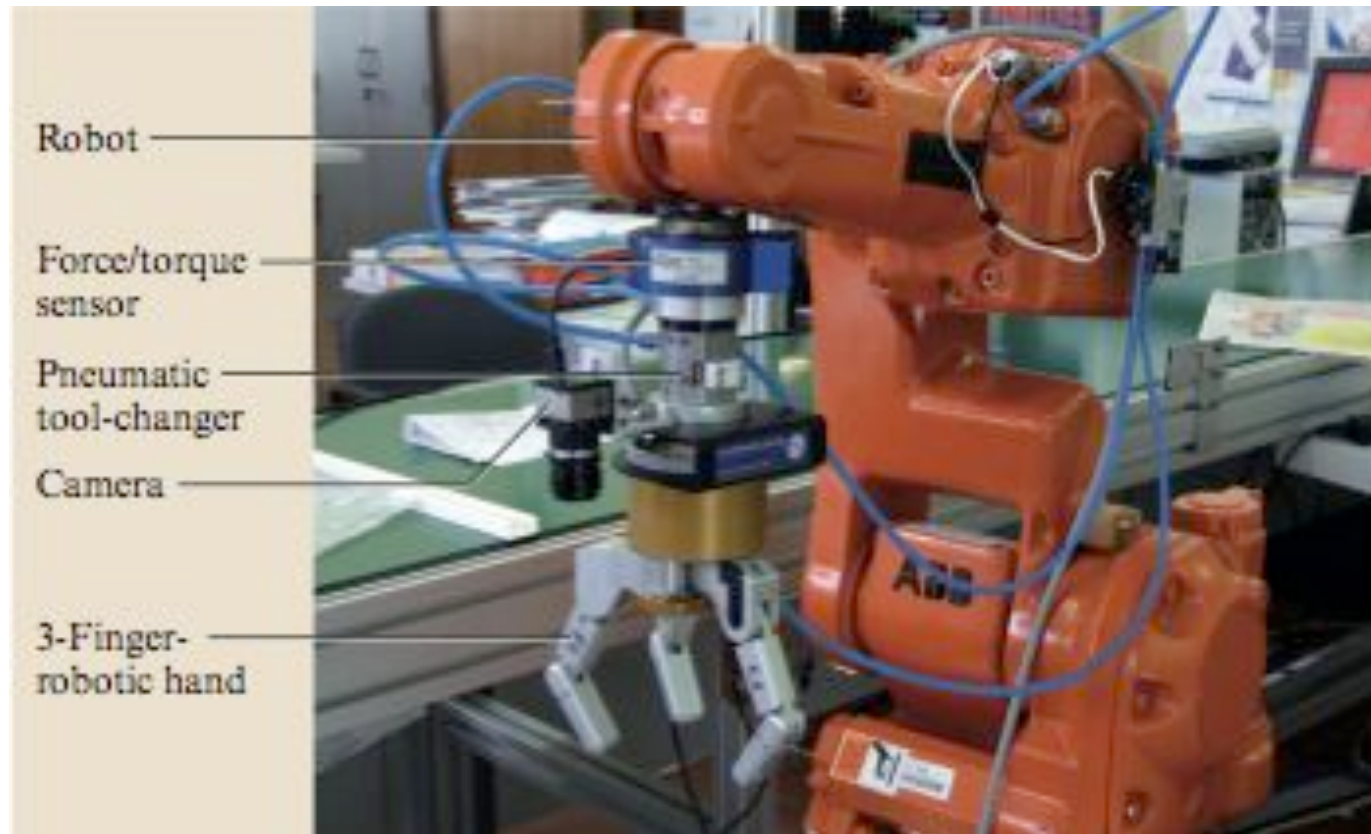



Calibration of robot kinematics

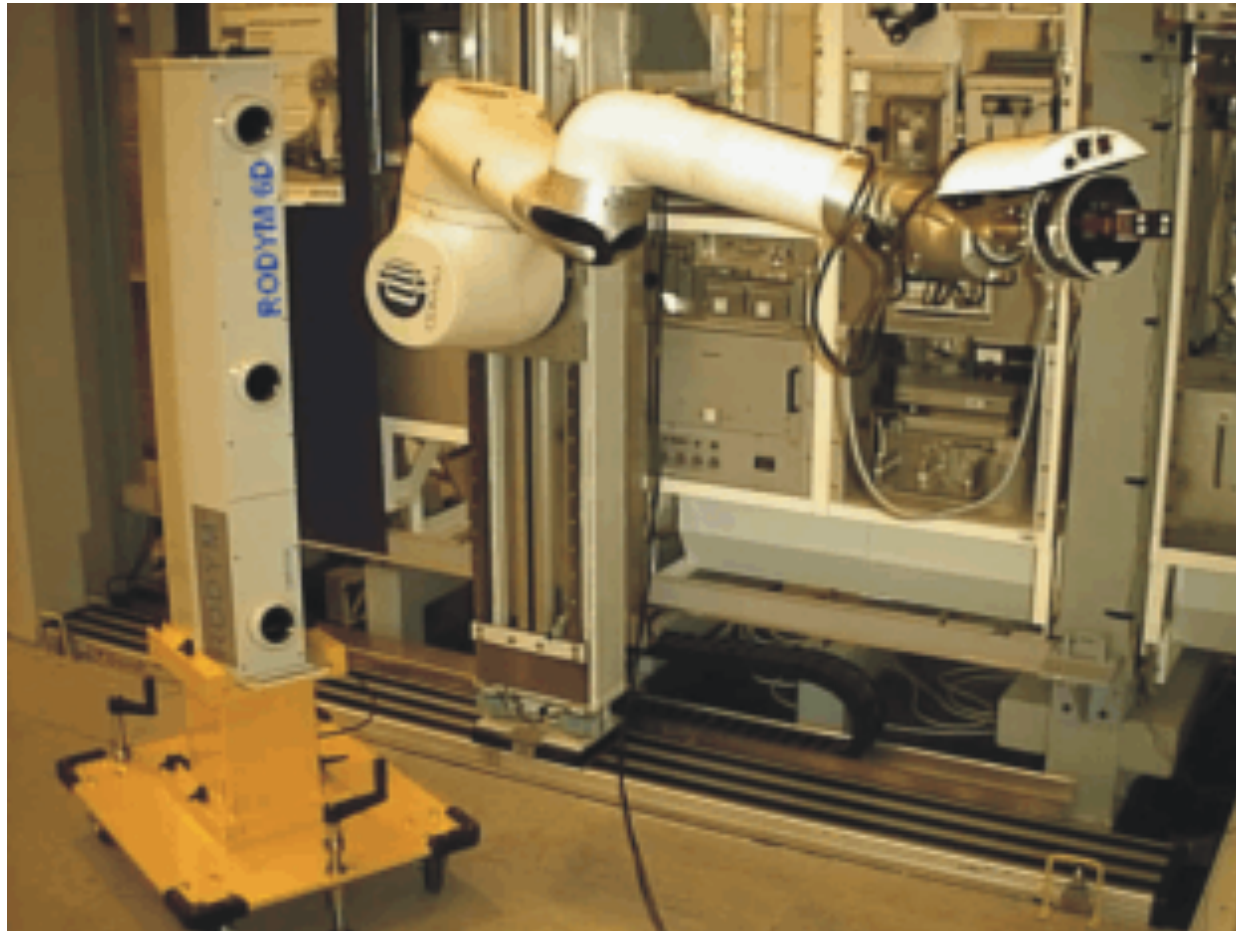



Man-machine interface



- teach-box pendant used as robot programming interface



- cabinet with power electronics for robot supervision and control



Programming and control environment

control modules
and interfaces
(Reis Robotics)

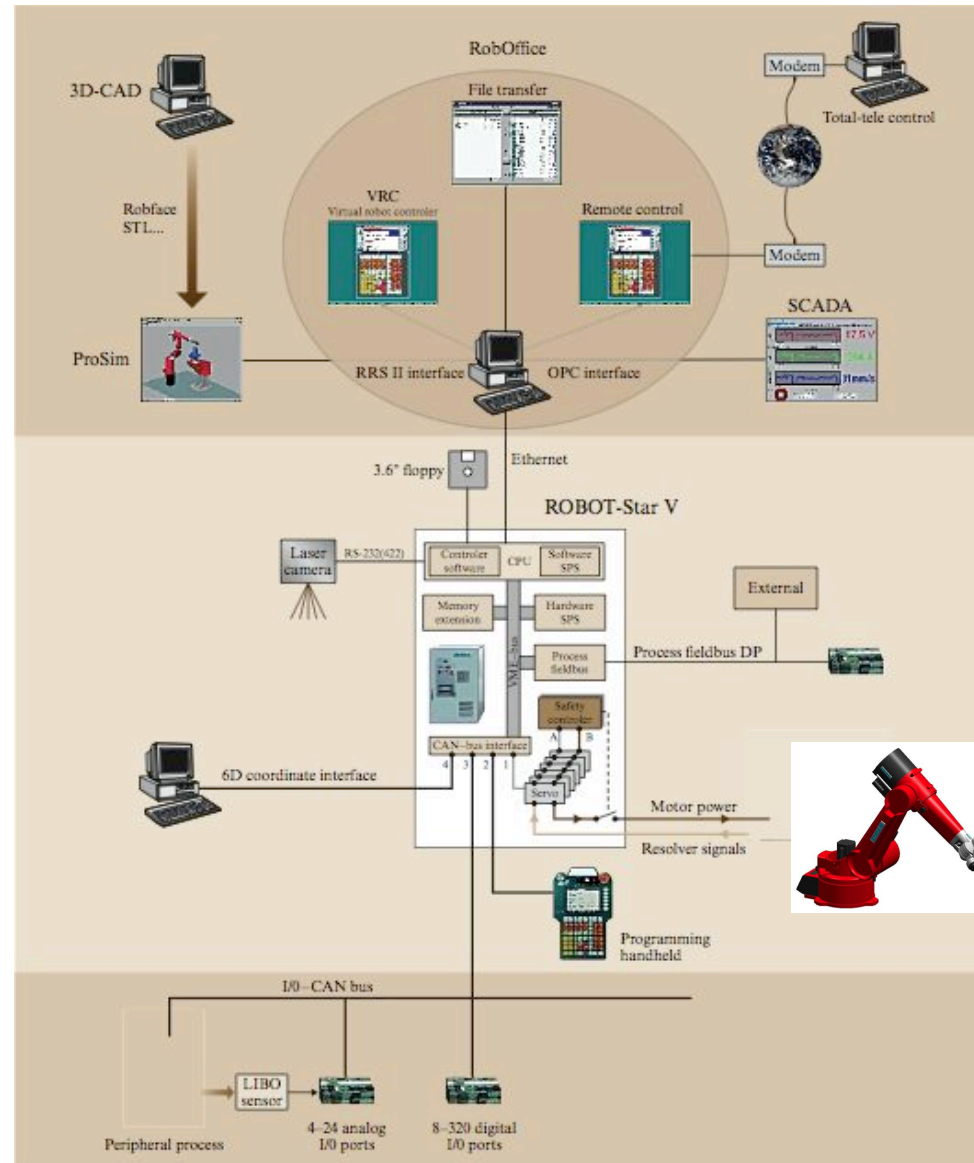



Motion programming and scaling



commercial [video](#) from ABB
TrueMove & QuickMove fast motion control performance



Mobile base robots in industry



- **AGV** (Automated Guidance Vehicles) for material and parts transfer on the factory floor: wire- or laser-driven along predefined paths



Lifting AGV for warehouses



video by Elettric80



Kiva Systems

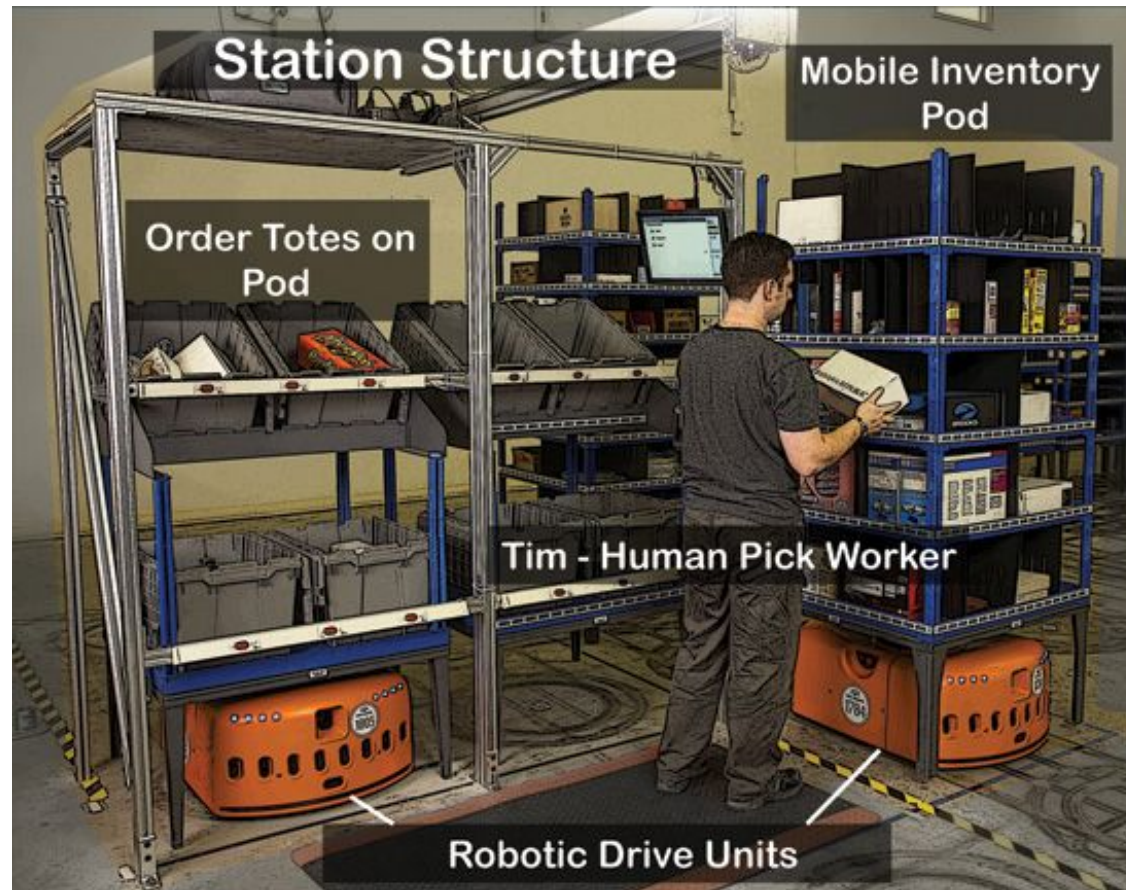

company acquired for \$775 million by Amazon (**store automation**)



Intelligent AGV in factories



commercial [video](#) of ADAM mobile robot (RMT Robotics)