

Kawasaki S030 robot – DH frames assignment and table

Name: _____

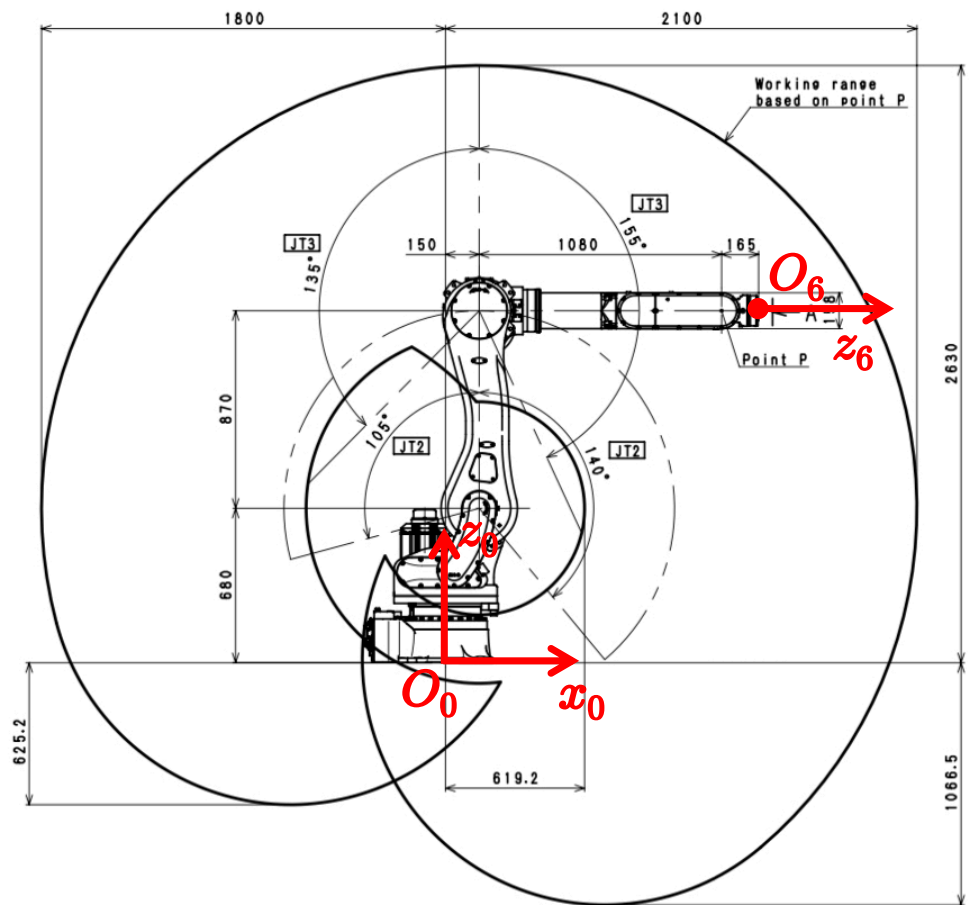
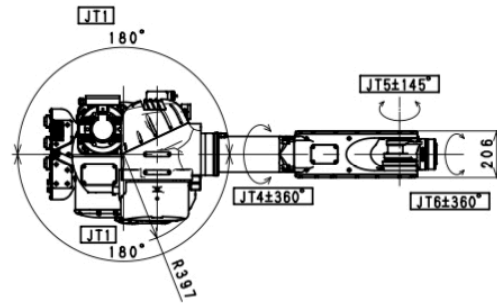
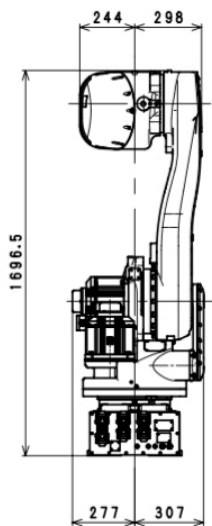

i	α_i	a_i	d_i	θ_i	$\theta_{i,\min}$	$\theta_{i,\max}$
1						
2						
3						
4						
5						
6						